

Kit Contents

Item #	Quantity Req'd.	Description
1	1	Front Crossbar
2	1	Rear Crossbar
3	4	Crossbar Covers

Hardware Kit Contents

Item #	Quantity Req'd.	Description
1	1	Torque Tool
2	1	User's Manual
3		
4		
5		

1. Remove Covers

⚠ NOTE: Be careful during installation to prevent scratching of roof rails and vehicle roof. Cover vehicle with a protective covering.

STOP (a) Locate 4 covers on side rails on roof of vehicle (Fig. 1-1).

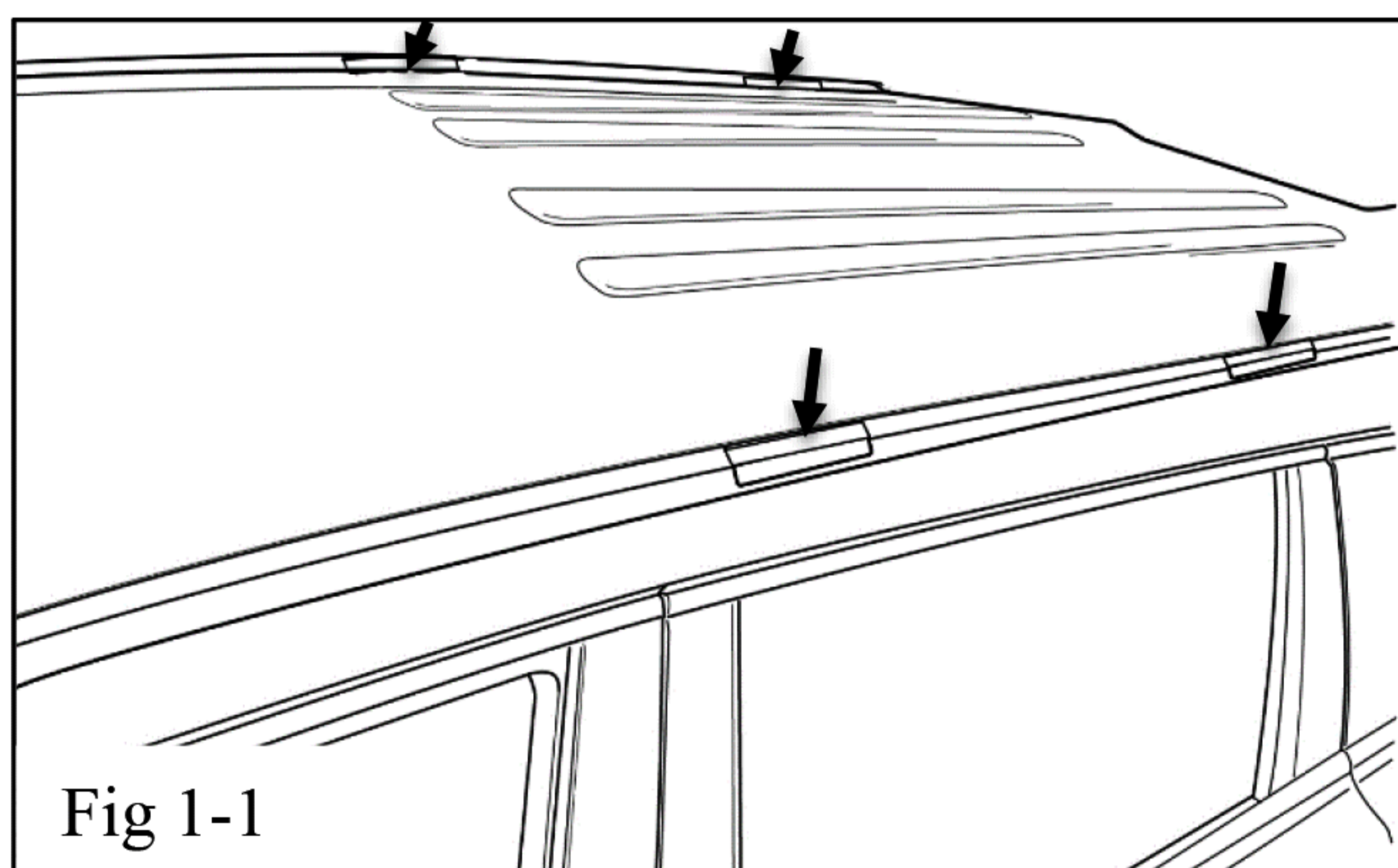

🔧 (b) Use Trim Removal tool to remove side rail caps by prying up from inner side and rotating outward as shown (Fig. 1-2). Place the caps in the supplied plastic bag and retain for use in Step 4.

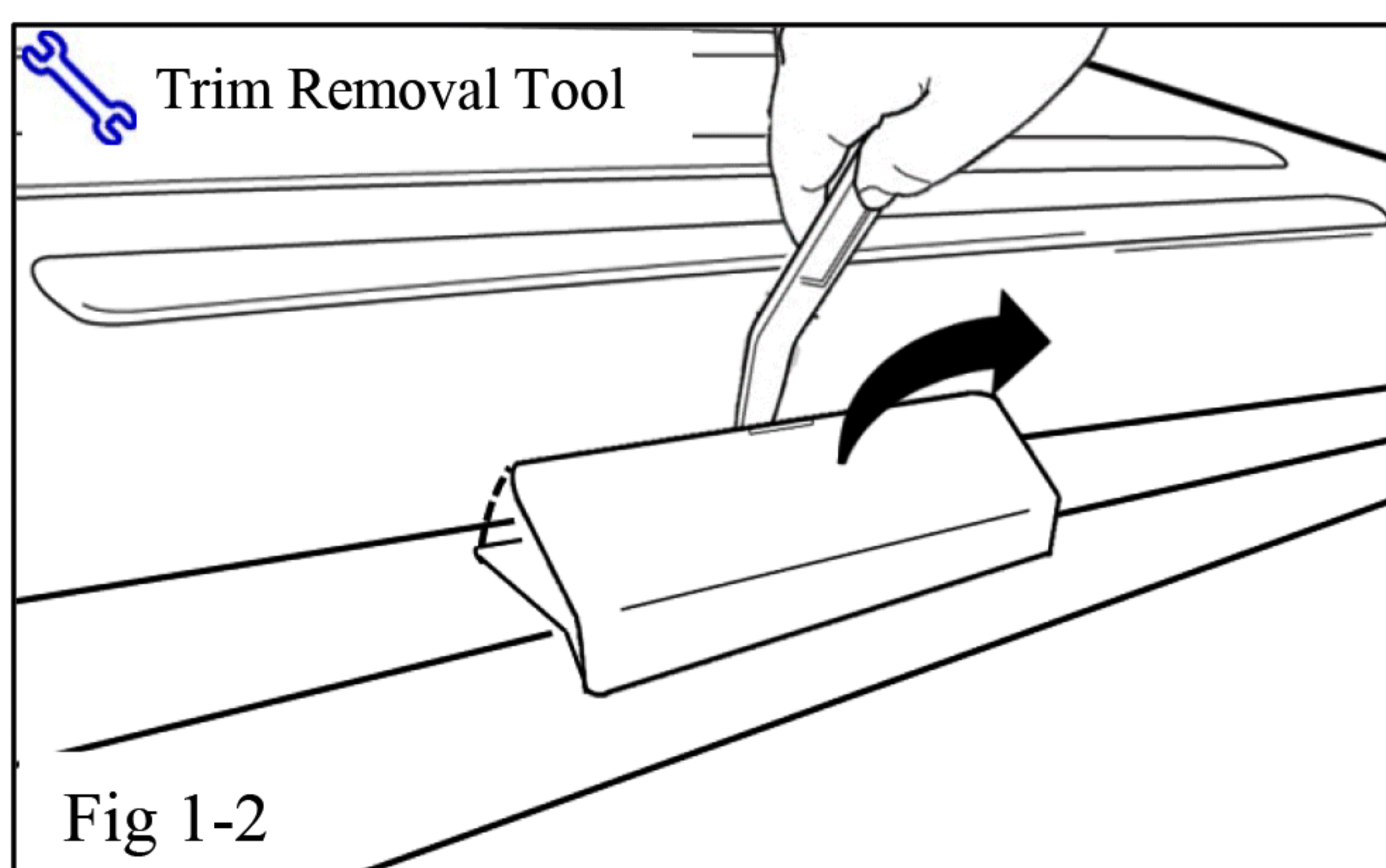

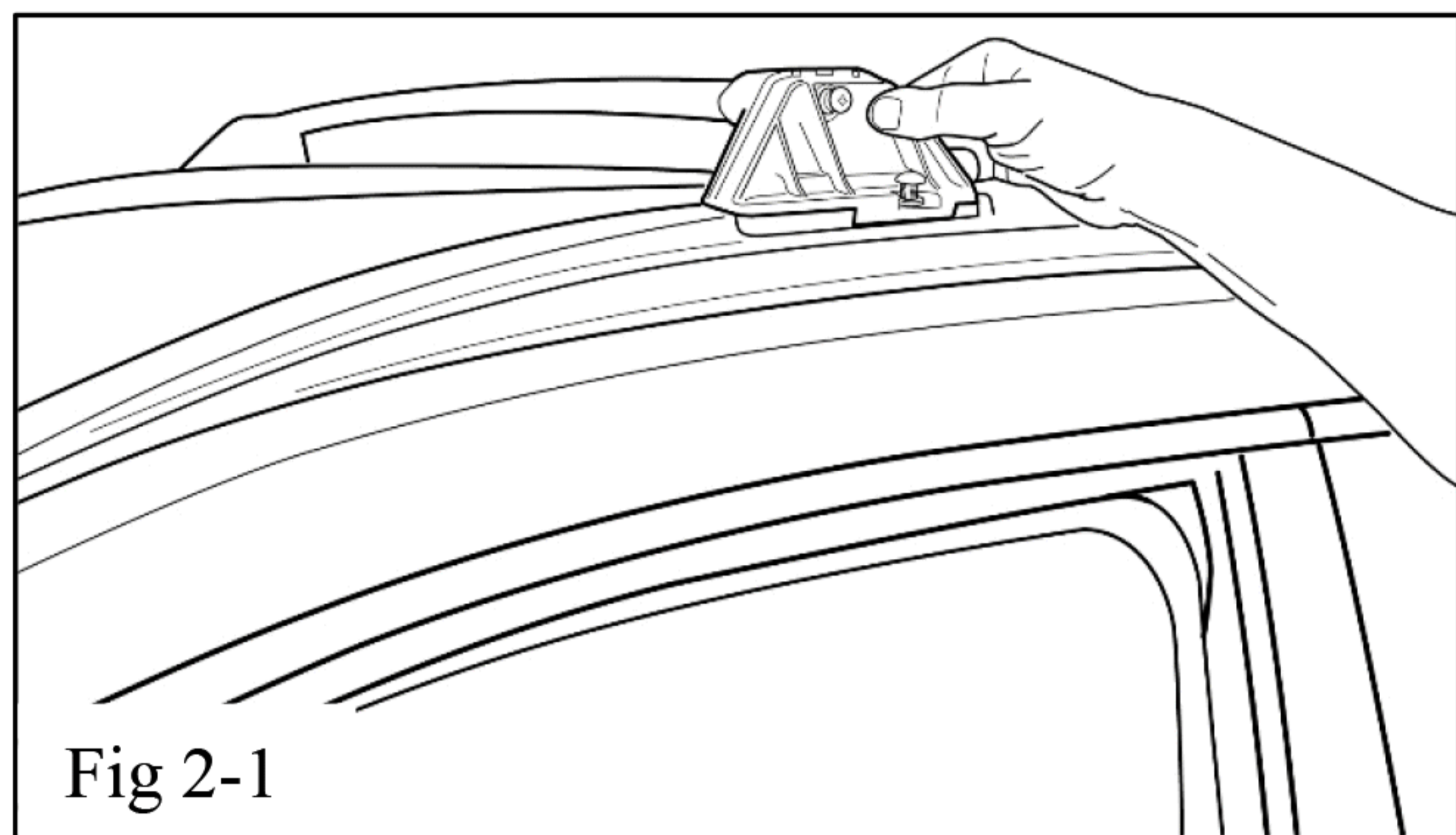

Fig 2-1

2. Install Crossbars

- (a) Place crossbar over roof side rails aligning the bolt in the stanchion over the threaded hole in the roof side rail (Fig. 2-1).

STOP **NOTES: Ensure crossbars are in correct position by designations on stanchions LHF, RHF, and LHR, RHR.**

- (b) Hand start the bolt into the threaded hole in the roof side rail.

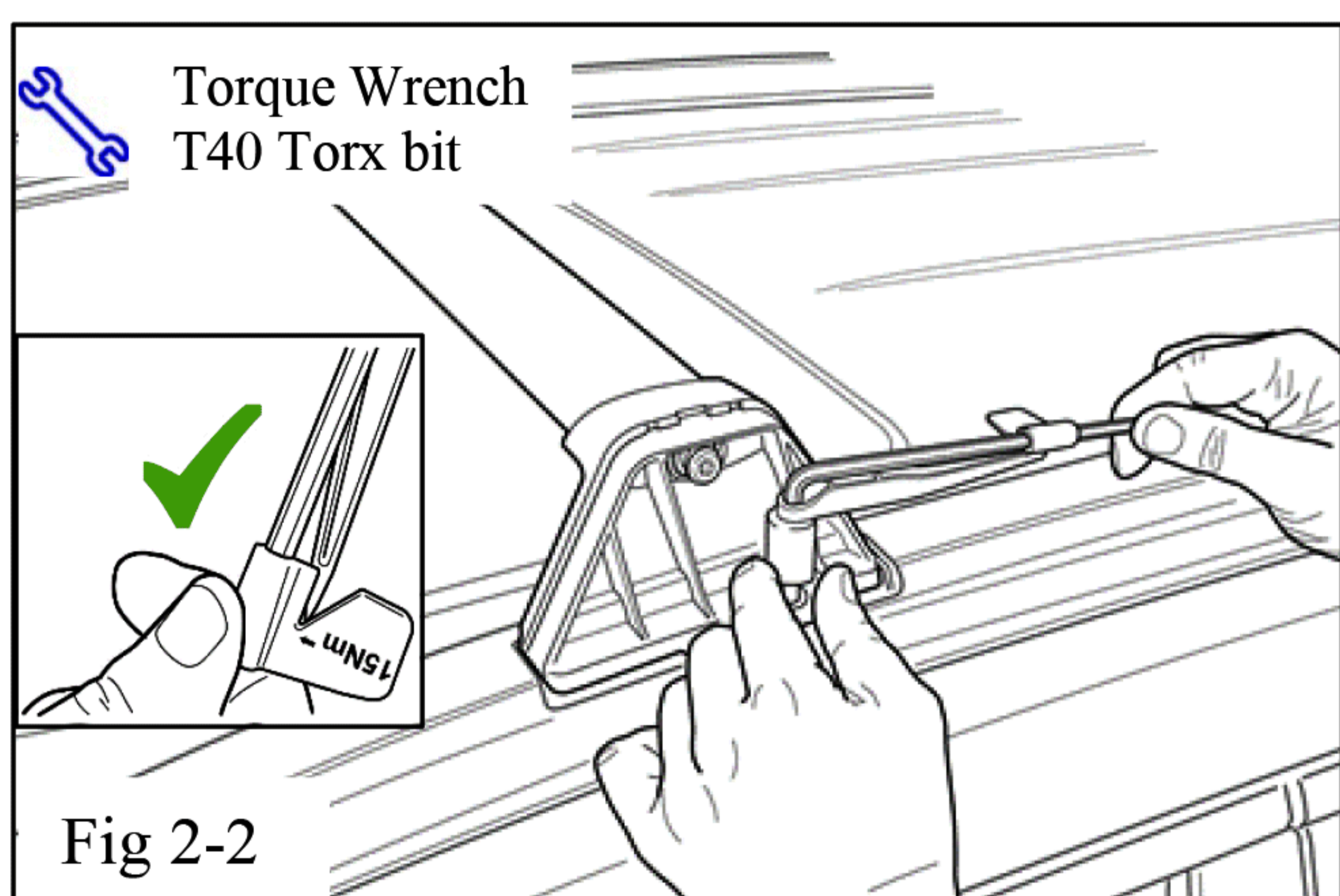

Fig 2-2

- Torque Wrench T40 Torx bit**
- (c) Torque the T40 bolts to 15 N-m (11 ft-lbs) (133 in-lbs) (Fig. 2-2).

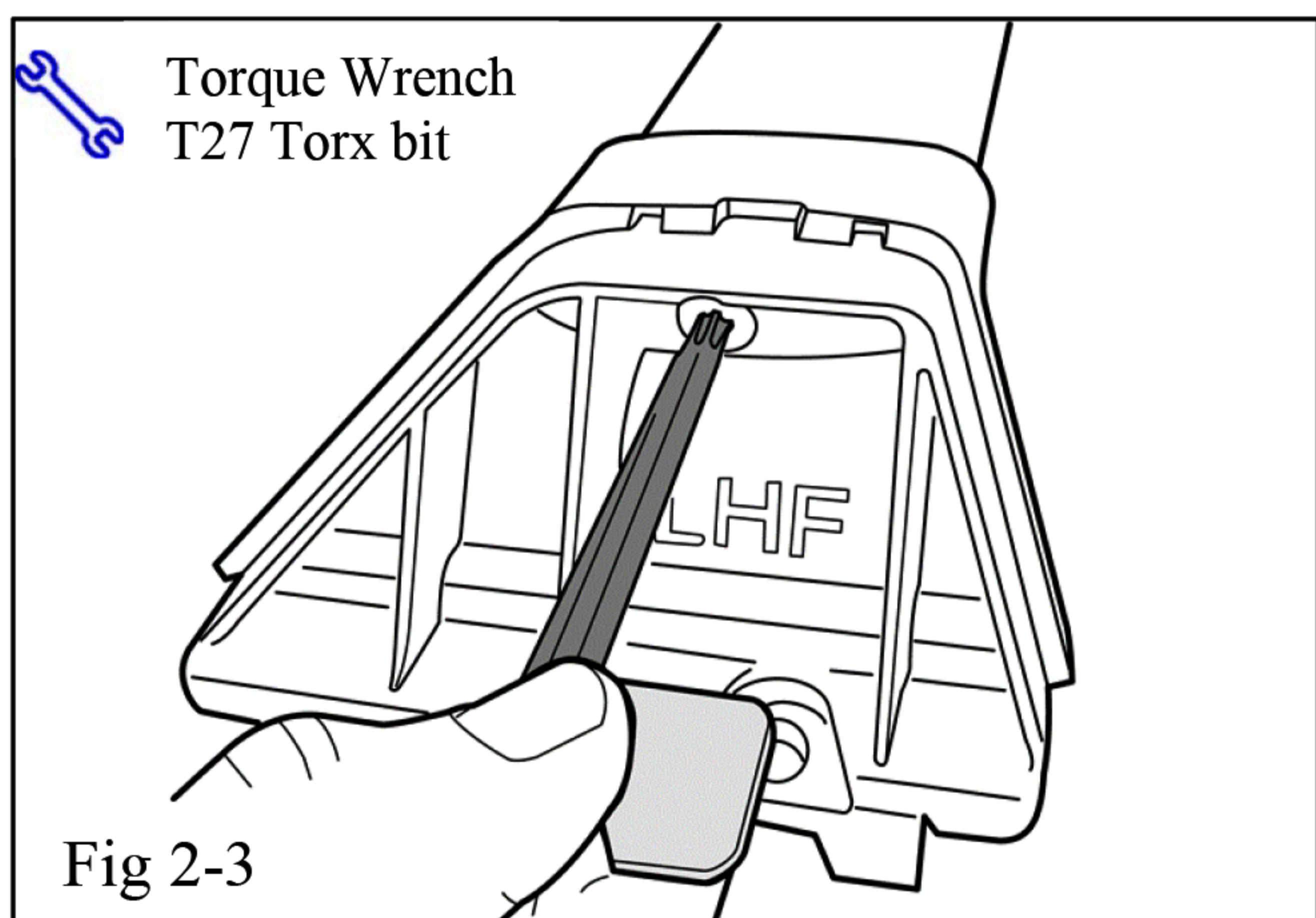
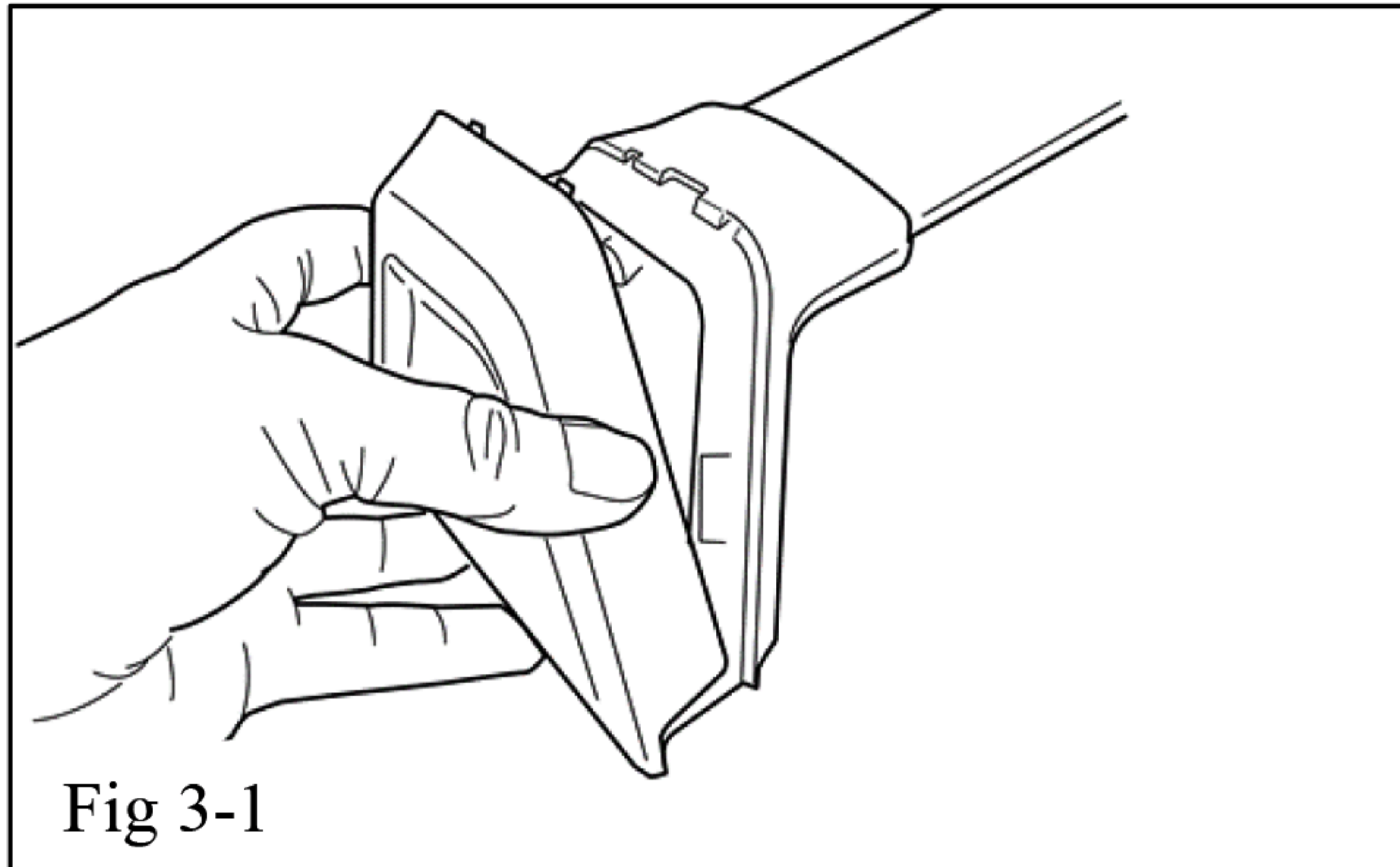

Fig 2-3

- Torque Wrench T27 Torx bit**
- (d) Torque the T27 crossbar attachment bolts on the LH side to 2.5 N-m (1.8 ft-lbs) (22 in-lbs) (Fig. 2-3).

3. Install Covers Onto Crossbars.



- (a) Identify the corresponding crossbar stanchion cover (LHF/LHR,RHF,RHR) and align with the bottom of the stanchion (Fig. 3-1).

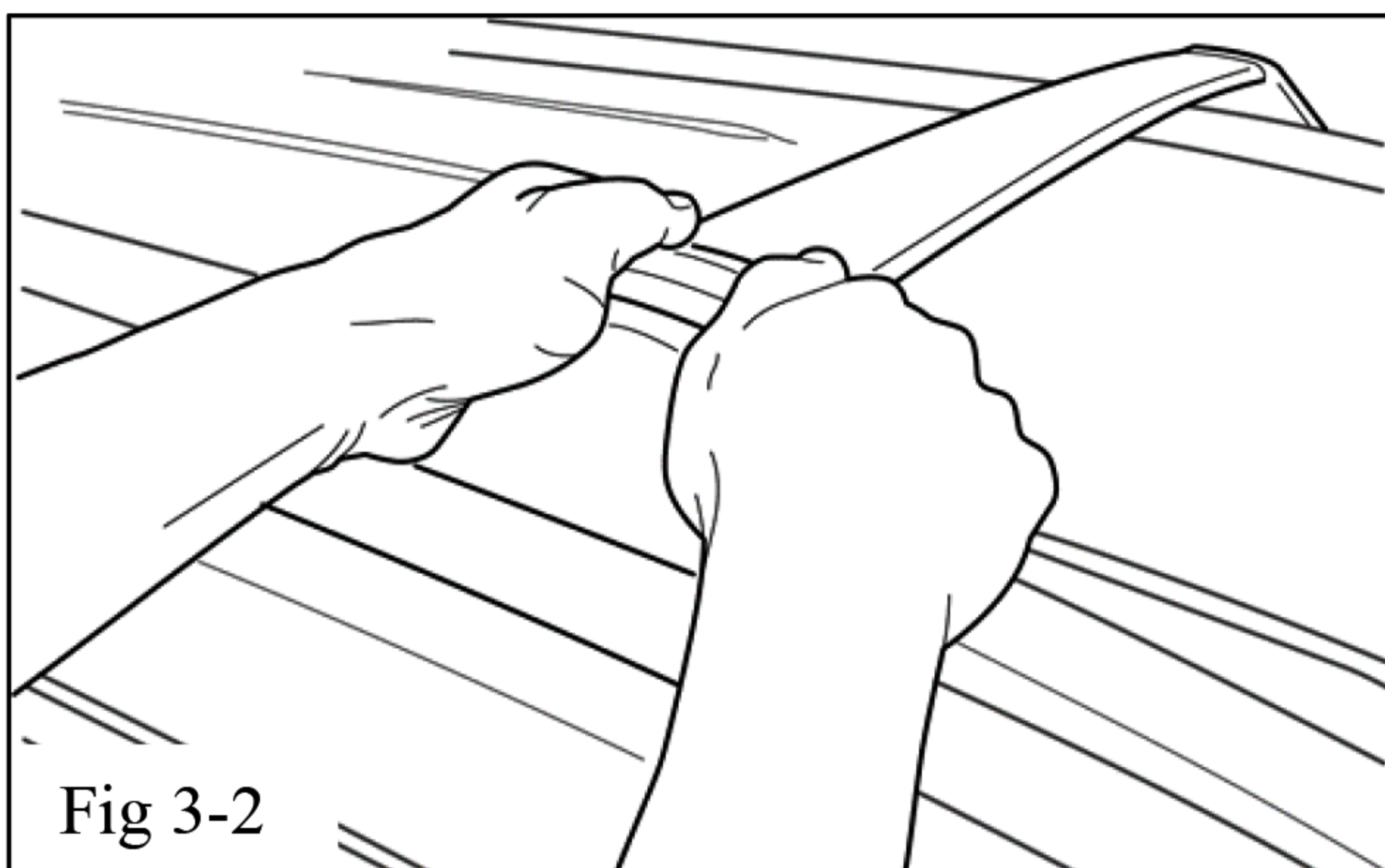

- (b) Rotate the top of the cover toward the stanchion and use both hands to firmly press to snap the top and side tabs into place (Fig. 3-2).

⚠ NOTE: Check the fit of the cover to the stanchion to ensure covers are seated properly at top and along all edges after snapping into place.

- (c) Repeat steps (2) through (3) with the second crossbar.

4. Complete Installation

- || Place the torque wrench, user's manual and bag with the side rail caps in the supplied plastic bag.
- || Place this bag in the glove box.