

INSTALLATION INSTRUCTIONS

SIDE ROCKER

JEEP WRANGLER JL 2018 (4 DOOR)

PART# PW027567

PARTS LIST:

1	Driver/left Side Armor	6	8mm x 28mm x 3mm Flat Washers
1	Passenger/right Side Armor	12	6-1.0mm x 25mm Hex Bolts
6	8-1.25mm x 35mm Hex Bolts	24	6mm x 2mm x 2mm Flat Washers
6	8mm Lock Washers	12	6-1.0mm Nylon Lock Nuts

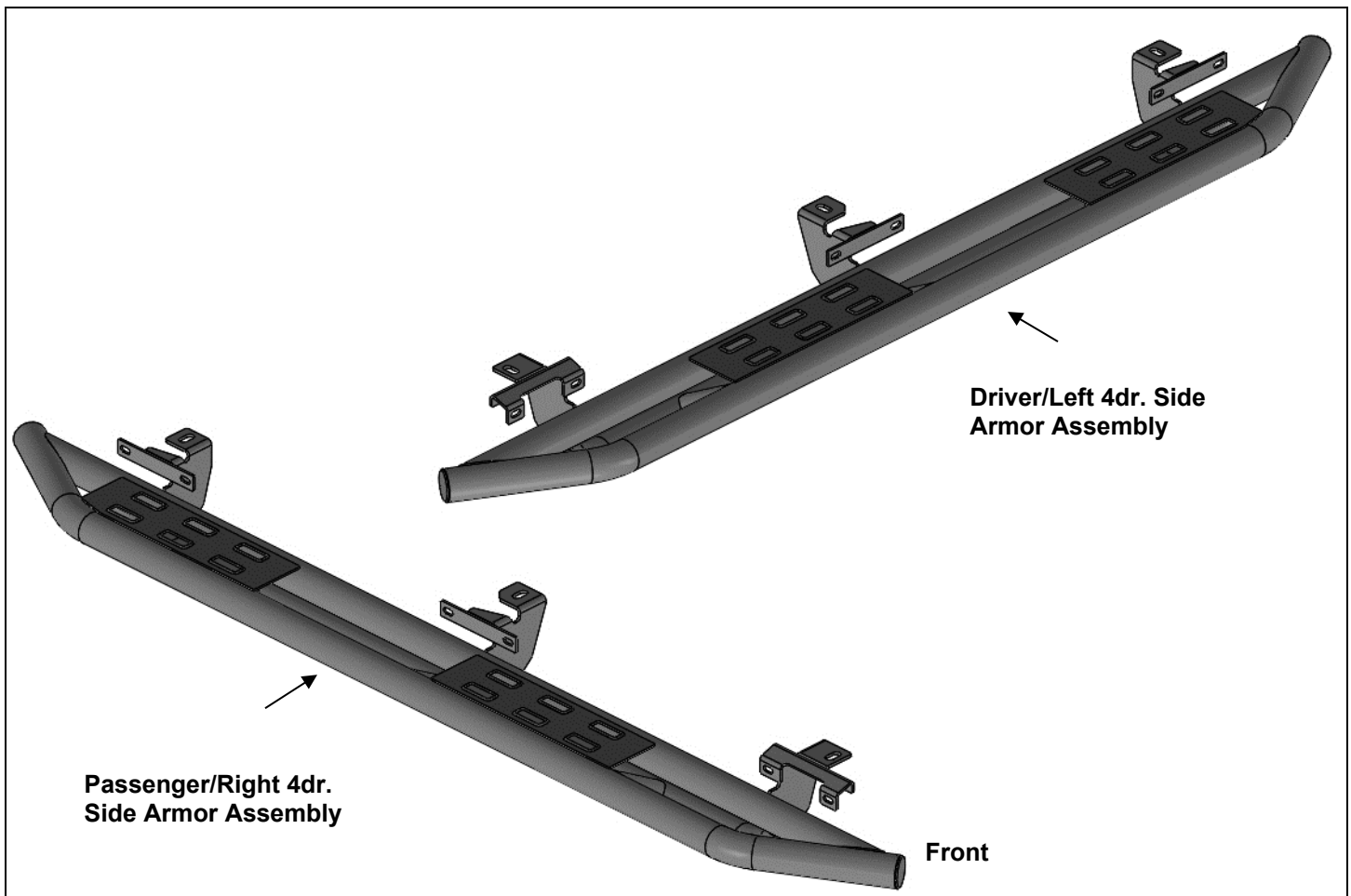
**PROCEDURE:**

- 1. REMOVE CONTENTS FROM BOX. VERIFY ALL PARTS ARE PRESENT. READ INSTRUCTIONS CAREFULLY. FACTORY INSTALLED OR AFTERMARKET "ROCK RAILS," SIDE STEPS OR RUNNING BOARDS MUST BE REMOVED. ASSISTANCE IS HIGHLY RECOMMENDED.**
- Start installation on the driver/left side of the vehicle. Locate the (3) pairs of factory mounting holes along the pinch weld, **(Figure 1)**. The mounting brackets on the Side Armor attach to the holes in the pinch weld and the small factory threaded hole directly behind the pinch weld, **(Figures 2—4)**.
- With assistance, hold the Driver/left Side Armor up in place against the back of the pinch weld. Line up the (3) welded brackets with the (6) factory holes in the pinch weld. Bolt the brackets to the **back** of the pinch weld with the included (6) 6mm x 25mm Hex Bolts, (12) 6mm Flat Washers and (6) 6mm Nylon Lock Nuts, **(Figures 5—8)**. Leave hardware loose at this time. **NOTE:** Insert Bolts from outside the pinch weld and out through the Bracket.
- Bolt each top tab on the Side Armor to the vehicle with the included (1) 8mm x 35mm Hex Bolt, (1) 8mm Lock Washer and (1) 8mm Flat Washer, **(Figures 5—8)**. Repeat for all locations.
- Level and adjust the Side Armor and tighten all hardware.
- Repeat **Steps 2—5** for Passenger Side Armor installation.

7. Do periodic inspections to the installation to make sure that all hardware is secure and tight.

To protect your investment, wax this product after installing. Regular waxing is recommended to add a protective layer over the finish. Do not use any type of polish or wax that may contain abrasives that could damage the finish. Mild soap may be used to clean the Side Armor.

Driver/Left Side Installation Pictured



(Fig 1) Locate the (3) factory pair of holes along the pinch weld (Driver/left side pictured)

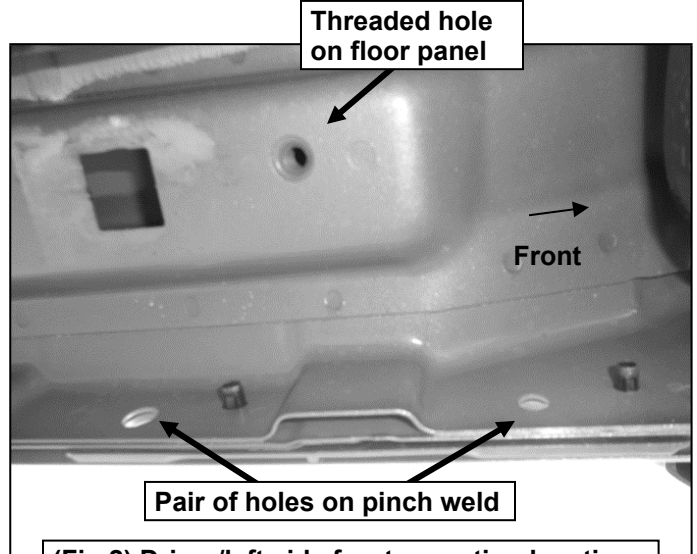

(Fig 2) Driver/left side front mounting location

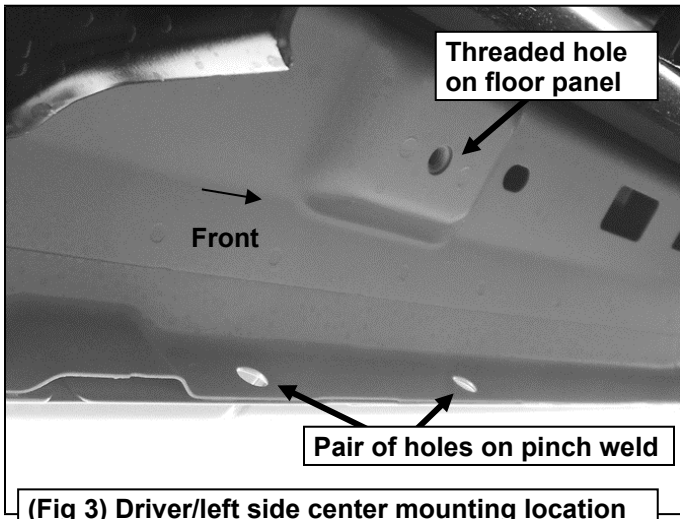

(Fig 3) Driver/left side center mounting location

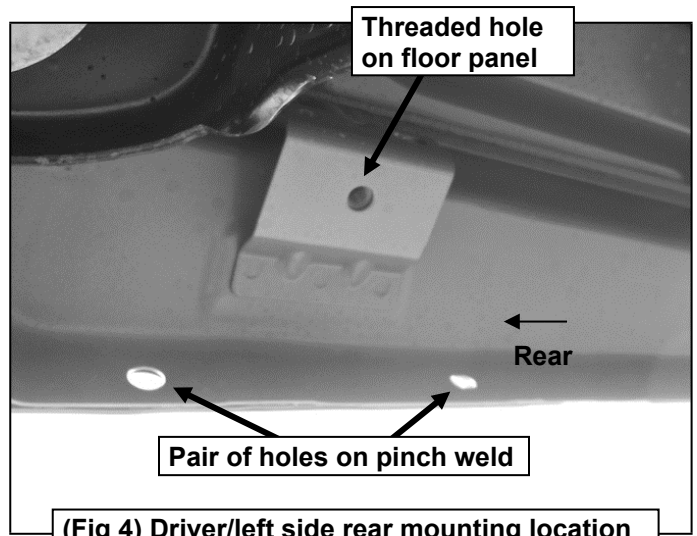

(Fig 4) Driver/left side rear mounting location

Driver/Left Side Installation Pictured

- (2) 6mm x 25mm Hex Bolts
- (4) 6mm Flat Washers
- (2) 6mm Nylon Lock Nuts

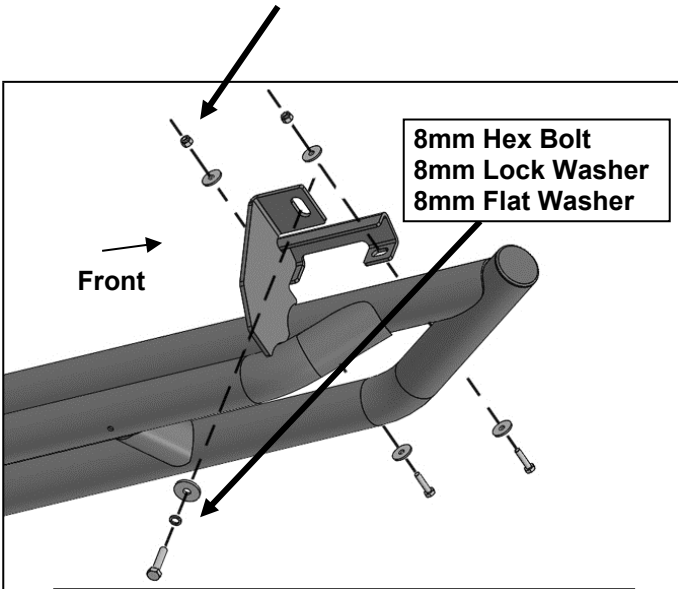

(Fig 5) Driver/left side front welded Bracket attached to pinch weld and inner floor panel

- (2) 6mm x 25mm Hex Bolts
 - (4) 6mm Flat Washers
 - (2) 6mm Nylon Lock Nuts
- 8mm Hex Bolt
8mm Lock Washer
8mm Flat Washer

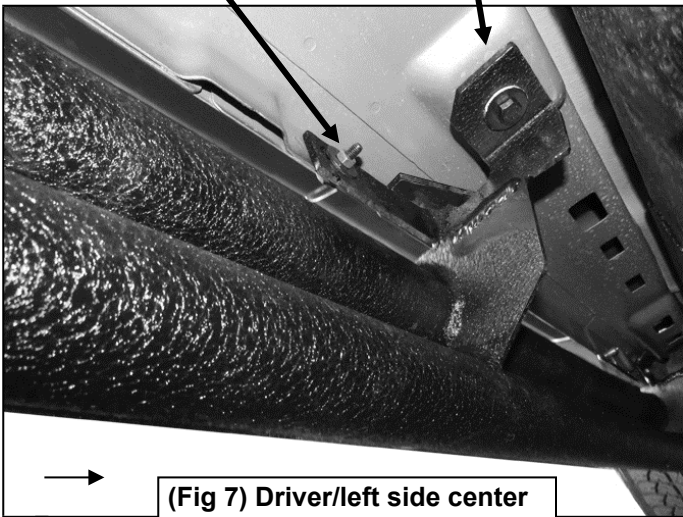

(Fig 7) Driver/left side center welded Bracket installed

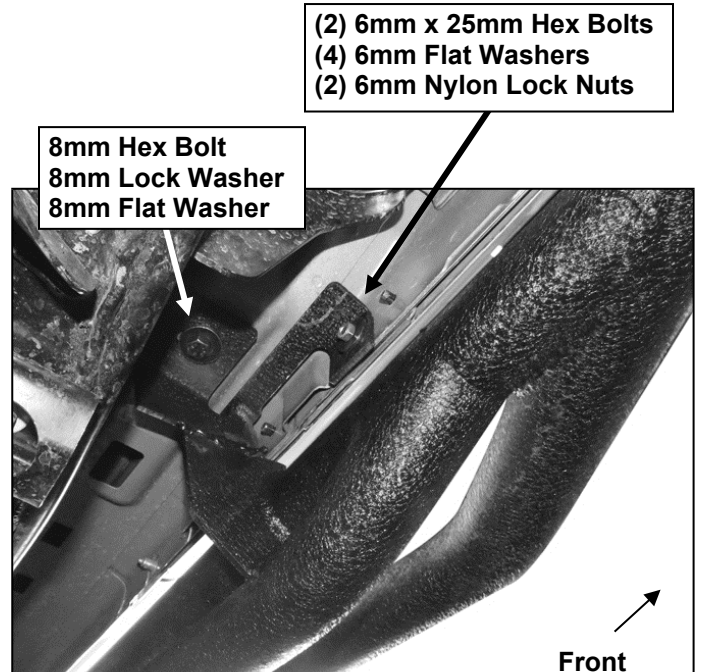

(Fig 6) Driver/left side front welded Bracket installed

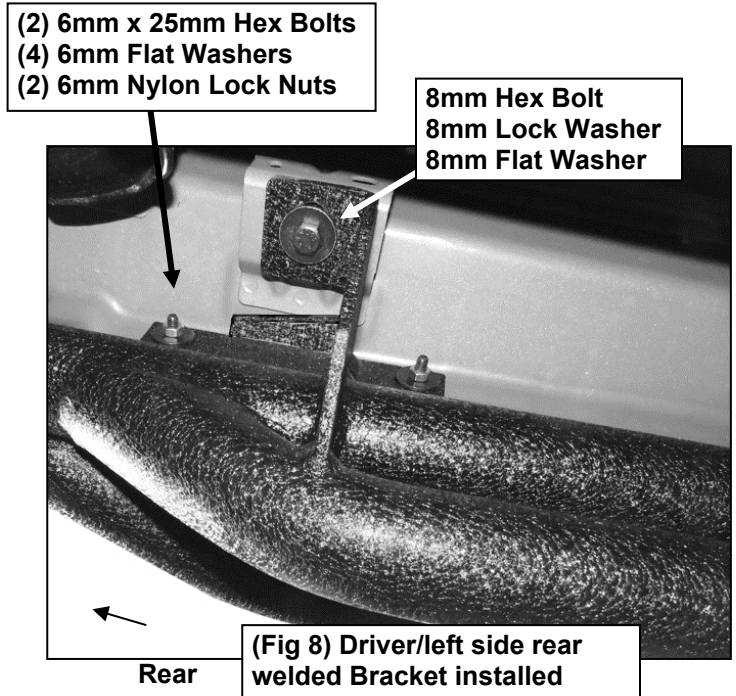

(Fig 8) Driver/left side rear welded Bracket installed