

13367

TOYOTA FJ CRUISER

7/16/2012

GROSS LOAD CAPACITY WHEN USED AS A WEIGHT CARRYING HITCH: 5000 LBS. TRAILER WEIGHT & 500 LBS. TONGUE WEIGHT.
 GROSS LOAD CAPACITY WHEN USED AS A WEIGHT DISTRIBUTION HITCH: 6000 LBS. TRAILER WEIGHT & 600 LBS. TONGUE WEIGHT

DO NOT EXCEED VEHICLE MANUFACTURER'S RECOMMENDED TOWING CAPACITY.

HAVING INSTALLATION QUESTIONS? CALL TECHNICAL SUPPORT AT 1-800-798-0813

Parts List			
ITEM	QTY	PART NUMBER	DESCRIPTION
1	2	7/16-14 x 1 1/2	CARRIAGE BOLT
2	2	CM-SP2	.250 x .88 x 2.25" SQUARE HOLE SPACER
3	2	7/16-14	LARGE HEX FLANGE NUT
4	2	3/8"	CONICAL TOOTHED WASHER
5	2	M8 - 1.25 x 30 HEX BOLT	HEX HEAD BOLT
6	4	M12-1.25 x 30mm	HEX TAP BOLT
7	4	1/2"	CONICAL TOOTHED WASHER
8	1	CM-438-FW	7/16" FISHWIRE TOOL

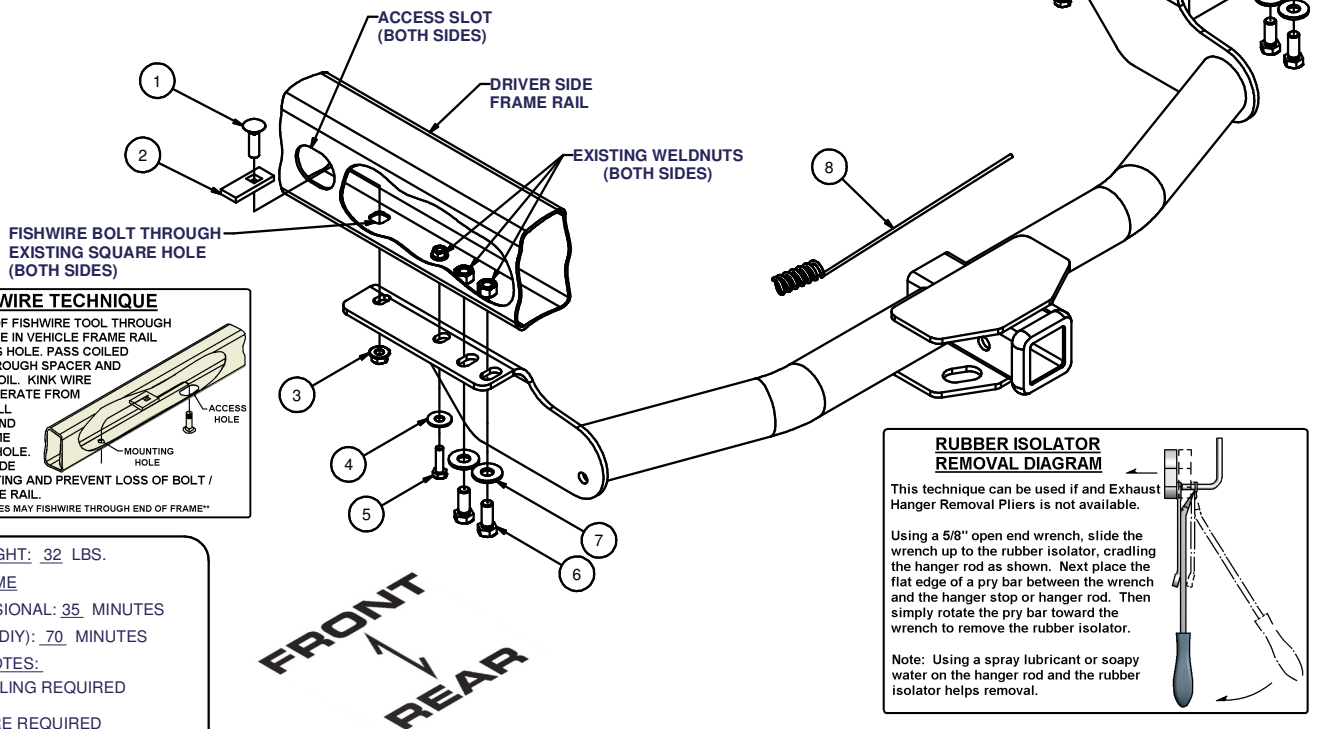
**FISHWIRE TECHNIQUE**

INSERT COILED END OF FISHWIRE TOOL THROUGH HITCH MOUNTING HOLE IN VEHICLE FRAME RAIL AND OUT THE ACCESS HOLE. PASS COILED END OF FISHWIRE THROUGH SPACER AND THREAD BOLT INTO COIL. KINK WIRE TO KEEP SPACER SEPERATE FROM BOLT AS SHOWN. PULL FISHWIRE, SPACER, AND BOLT THROUGH FRAME AND OUT MOUNTING HOLE. USE FISHWIRE TO GUIDE HITCH DURING MOUNTING AND PREVENT LOSS OF BOLT / SPACER INSIDE FRAME RAIL.
 NOTE: SOME VEHICLES MAY FISHWIRE THROUGH END OF FRAME

RUBBER ISOLATOR REMOVAL DIAGRAM

This technique can be used if and Exhaust Hanger Removal Pliers is not available.

Using a 5/8" open end wrench, slide the wrench up to the rubber isolator, cradling the hanger rod as shown. Next place the flat edge of a pry bar between the wrench and the hanger stop or hanger rod. Then simply rotate the pry bar toward the wrench to remove the rubber isolator.

Note: Using a spray lubricant or soapy water on the hanger rod and the rubber isolator helps removal.

HITCH WEIGHT: 32 LBS.

INSTALL TIME

PROFESSIONAL: 35 MINUTES

NOVICE (DIY): 70 MINUTES

INSTALL NOTES:

- NO DRILLING REQUIRED

- FISHWIRE REQUIRED

INSTALLATION STEPS

- 1) Remove tow hook(s) if present, and return to owner.
- 2) Lower exhaust, (temporarily lowering the (3) rearmost exhaust hangers will provide enough clearance for bolt installation.)
- 3) Raise hitch into position, with passenger side plate above exhaust pipe. Loosely install the 12MM hex bolts into the existing weldnuts in frame rails.
- 4) Fishwire the 7/16" carriage bolts and square hole spacers into position using the existing access holes as shown. Install remaining M8 fasteners.
- 5) Torque all M8 fasteners to 23 lb-ft, all 7/16" fasteners to 70 lb-ft, and all M12 fasteners to 86 lb-ft.
- 6) Re-install exhaust hangers to original position.

PERIODICALLY CHECK THIS RECEIVER HITCH TO ENSURE THAT ALL FASTENERS ARE TIGHT AND THAT ALL STRUCTURAL COMPONENTS ARE SOUND.

Curt Manufacturing Inc., warrants this product to be free of defects in material and/or workmanship at the time of retail purchase by the original purchaser. If the product is found to be defective, Curt Manufacturing Inc., may repair or replace the product, at their option, when the product is returned, prepaid, with proof of purchase. Alteration to, misuse of, or improper installation of this product voids the warranty. Curt Manufacturing Inc.'s liability is limited to repair or replacement of products found to be defective, and specifically excludes liability for incidental or consequential loss or damage.

78215 / 757367