



Safety glasses should be worn at all times while installing this product.

YEARS: 2013-PRESENT

MAKE: BMW

MODEL: X1 WITH PANORAMIC SUNROOF ONLY

STYLE: CROSSOVER

WARNING: NEVER EXCEED YOUR VEHICLE MANUFACTURER'S RECOMMENDED TOWING CAPACITY

WEIGHT CARRYING:
 TRAILER WEIGHT: 2,500 LBS.
 TONGUE WEIGHT: 250 LBS.

WARNING:
 WE RECOMMEND THE USE OF 18050 STABILIZING STRAPS FOR ALL NON-TRAILER (WHEEL-LESS) LOADS. PLEASE SEE THE CURT CATALOG OR VISIT US ONLINE AT WWW.CURTMFG.COM FOR FURTHER INFORMATION.

INSTALLATION TIME: 40/80 MIN.

THE INSTALL TIME LISTED IS FOR PROFESSIONAL INSTALLERS. IF YOU ARE HESITANT TO UNDERTAKE THIS TASK ON YOUR OWN, CONTACT AN AUTHORIZED CURT INSTALLER FOR ADDITIONAL ASSISTANCE.

INSTALLATION REQUIRES:

RATCHET	8mm 18mm 19mm 11/16" SOCKET	TORQUE WRENCH
BOXED END WRENCH 11/16"	PLASTIC RIVET GUN	SCREW DRIVER
CENTER PUNCH	SAFETY GLASSES	

INSTALLATION TIPS:

- BEFORE YOU BEGIN INSTALLATION, READ ALL INSTRUCTIONS THOROUGHLY.
- TO EASE INSTALLATION, 2 PEOPLE MAY BE REQUIRED.
- USING PROPER TOOLS WILL GREATLY IMPROVE THE QUALITY OF THE INSTALL AND REDUCE THE TIME REQUIRED.
- NEED HELP OR HAVE SOME QUESTIONS? CALL TECHNICAL SUPPORT AT 800.798.0813

LEVEL OF DIFFICULTY: MODERATE

EASY	MODERATE	CHALLENGING
PART REMOVAL	REMOVE REAR FASCIA	
	NO DRILLING REQUIRED	

VEHICLE PHOTO:



REPRESENTATIVE PHOTO

HITCH ILLUSTRATION:

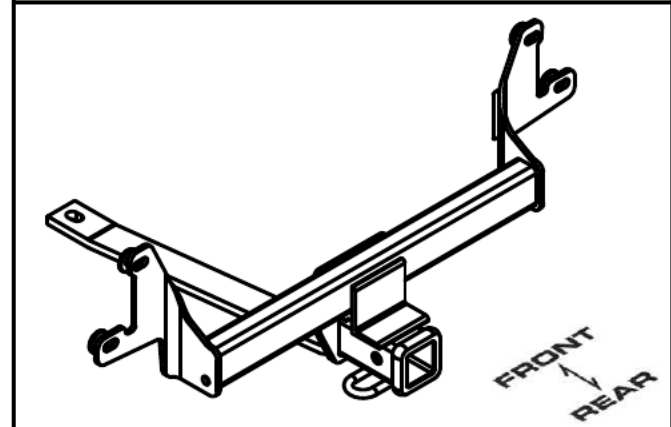

MAKE SURE YOUR HITCH MATCHES

PERIODICALLY CHECK THIS RECEIVER HITCH TO ENSURE ALL FASTENERS ARE TIGHT AND ALL STRUCTURAL COMPONENTS ARE SOUND

CURT Manufacturing LLC. warrants this product to be free of defects in material and/or workmanship at the time of retail purchase by the original purchaser. If the product is found to be defective, Curt Manufacturing LLC. may repair or replace the product at their option, when the product is returned, prepaid, with proof of purchase. Alteration to, misuse of, or improper installation of this product voids the warranty. Curt Manufacturing LLC.'s liability is limited to repair or replacement of products found to be defective, and specifically excludes liability for incidental or consequential loss or damage.

INSTALLATION WALKTHROUGH:

Parts List			
ITEM	QTY	PART NUMBER	DESCRIPTION
1	1	1/2"	CONICAL TOOTHED WASHER
2	2	CM-SP41	.188 x 1.38 x 1.50" ROUND HOLE SPACER
3	2	7/16-14	HEX FLANGE NUT
4	2	7/16-14 x 1 1/4	CARRIAGE BOLT
5	1	M12 - 1.50 x 60 HEX BOLT	HEX BOLT
6	28	7/16 WASHER	WASHER
7	2	M6 RIVET	NYLON RIVET (AUVECO #20754)

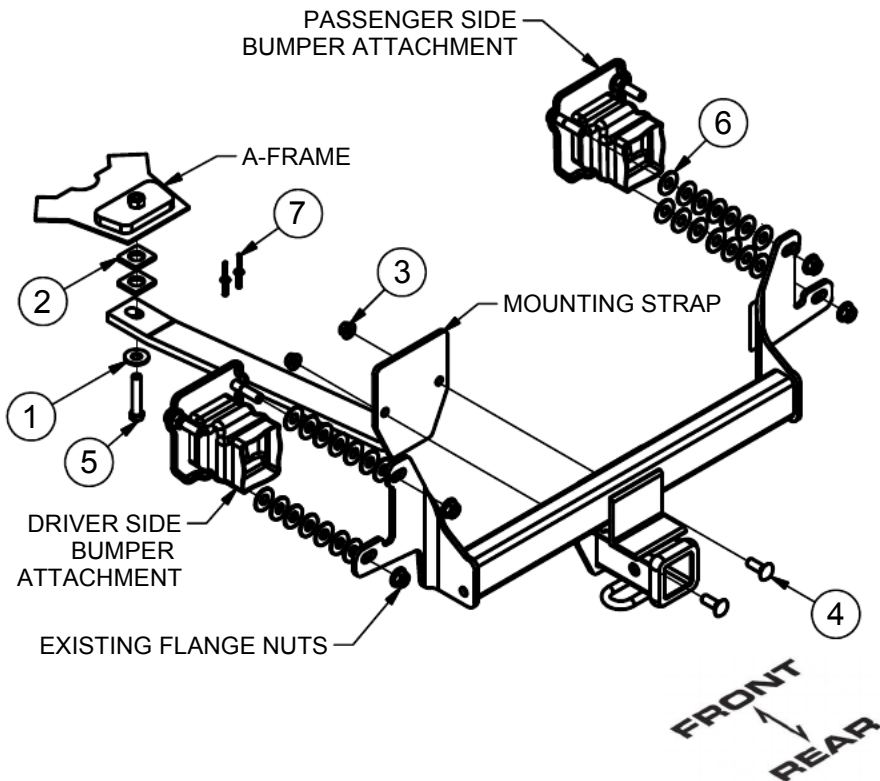

1. Remove (5) fasteners and (2) nylon rivets securing rear fascia. To remove rivets push small center rod through rivet with a small punch or an equivalent tool. Pry rivets from trim and pop trim off. Unplug back up sensors. **Note:** Replacement rivets are included.

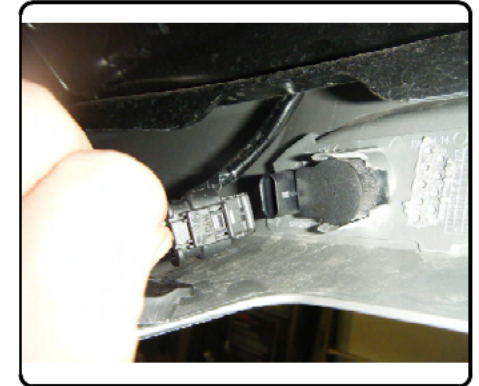

2. Remove four (4) 12mm nuts from the bumper attachments on both sides which will be reused in step # 3. Also remove a 12mm bolt from the A-frame and return it to the owner. Place (as many as needed) washers per stud between the bumper attachments and the hitch plates on both sides as shown.

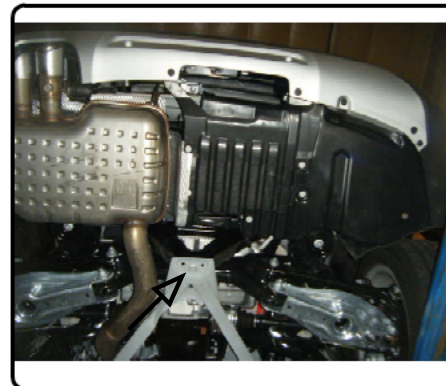

INSTALLATION WALKTHROUGH:

3. Lift the hitch into position over studs and secure with existing flange nuts as shown.



4. Attach mounting strap to the hitch using 7/16" fasteners as shown. Place two (2) spacers between the hitch and the A-frame, and secure with 12mm bolt and conical toothed washer as shown.



5. Torque all 12mm fasteners to 82 lb-ft, and all 7/16" fasteners to 70 lb-ft.



6. Reinstall the rear fascia panel. **Note:** A plastic rivet gun is required to fasten supplied rivets.

Install is now complete.



TOWING SAFETY INFORMATION

Gross Trailer Weight / GTW

The Gross Trailer Weight is the weight of the trailer & cargo. Measure this by putting the fully loaded trailer on a vehicle scale.

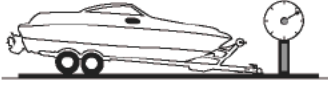

Tongue Weight / TW

The downward force that is exerted on the hitch ball by the coupler. The tongue weight will vary depending on where the load is positioned in relationship to the trailer axle(s). To measure the tongue weight, use either a commercial scale or a bathroom scale with the coupler at towing height. When using a bathroom scale with heavier tongue weights, use the method shown and multiply the scale reading by 3.

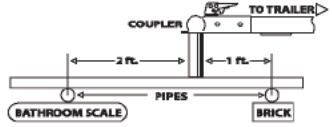

Weight Carrying / WC

The total weight of both the trailer and the cargo inside. Never exceed the weight capacity of your trailer hitch.

Weight Distribution / WD

Used to balance the weight of the cargo between the front and rear wheels throughout the trailer, allowing for better steering, braking, and level riding.



Sway Control

A device used to reduce the lateral movements of the trailer that are caused by the wind. This works in conjunction with a weight distribution hitch. Do not use this on a class 1 or 2 hitch, or with surge brakes.

How Much Can You Safely Tow?

TONGUE WEIGHT lbs	1000	2000	3000	4000	5000	6000	7000	8000	10,000	12,000
Tongue weight should be about 10 to 15 percent of the gross trailer weight.										
TRAILER TYPE	CLASS 1									
	CLASS 2									
	CLASS 3									
	CLASS 4									
	CLASS 5									
Camper	13'	12'	13'	14'	15'	16'				
lbs	1100	1200	1300	1400	1500	1600				
Vacation	14'	16'	18'	20'	22'	24'	26'	28'	30'	32'
lbs	2100	2400	2700	3000	3300	3600	3900	4200	4500	4800
Vacation	14'	16'	18'	20'	22'	24'	26'	28'	30'	32'
lbs	2800	3200	3600	4000	4400	4800	5200	5600	6000	6400
5th Wheel										

Refer to owner's manual for towing capabilities and limitations.

Ball Mount

The ball mount is placed inside the opening of the receiver hitch which is mounted to the vehicle. Make sure a hitch pin and clip is properly securing the ball mount to the receiver hitch before you begin towing.

- A: Rise. B: Drop. C: Hole Size. D: Length.

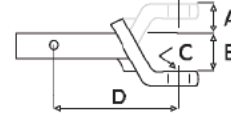

Trailer Ball

The connection from the hitch to the trailer. There are many factors that determine the correct hitch ball:

- Number one is the hitch ball's gross trailer weight rating.
- The mounting platform must be at least 3/8" thick.
- The hole diameter must not be more than 1/16" larger than the threaded shank.
- Every time you tow, check the nut and lock washer to make sure they are fastened securely.
- A: Ball Dia. B: Shank Dia. C: Shank Length. D: Shank Rise.

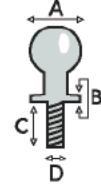

Coupler

The component that is placed over the trailer ball to connect the vehicle to the trailer. Be sure that the coupler size matches the size of the hitch ball and that the coupler handle is securely fastened. To determine what size hitch ball you need for your application you will need to know the size of coupler that is on the trailer. Be sure your coupler is properly adjusted to the ball you are using.

NOTE: For added security the use of safety devices such as Coupler Safety Pins and Locks is strongly recommended.

Safety Chains

Safety chains are a requirement and should be crossed under the tongue of the trailer so that the tongue will not drop to the road if it becomes separated from the hitch. Always leave enough slack so you can turn. Never allow the safety chains to drag on the ground and never attach the chains to the bumper.

Trailer Classification: Safety Chain Breaking Force - Minimum

Class 1: 2,000 lbs. (8.9 kN)

Class 2: 3,500 lbs. (15.6 kN)

Class 3: 5,000 lbs. (22.2 kN)

The strength rating of each length of safety chain or its equivalent and its attachments shall be equal to or exceed in minimum breaking force the GVWR (Gross Vehicle Weight Rating) of the trailer.

Electrical

Trailer lights, Electric Brakes, Break-away systems - Every time you tow, be sure to check that all components are working properly.

Wiring identification by color:

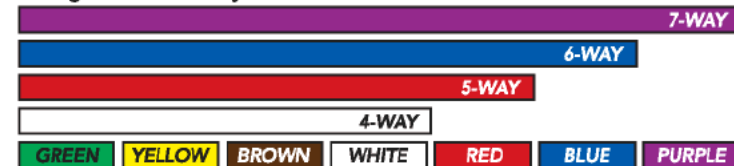

13140**BMW X1 WITH PANORAMIC SUNROOF ONLY****2/18/2013****GROSS LOAD CAPACITY WHEN USED AS A WEIGHT CARRYING HITCH: 2,500 LBS. TRAILER WEIGHT & 250 LBS. TONGUE WEIGHT.*******DO NOT EXCEED VEHICLE MANUFACTURER'S RECOMMENDED TOWING CAPACITY.*******WARNING: ALL NON-TRAILER LOADS APPLIED TO THIS PRODUCT MUST BE SUPPORTED BY AUXILIARY STABILIZING STRAPS.****** FAILURE TO PROPERLY SUPPORT NON-TRAILER LOADS WILL VOID PRODUCT WARRANTY******HAVING INSTALLATION QUESTIONS? CALL TECHNICAL SUPPORT AT 1-877-287-8634**

Parts List			
ITEM	QTY	PART NUMBER	DESCRIPTION
1	2	7/16-14 x 1 1/4	CARRIAGE BOLT
2	2	7/16-14	HEX FLANGE NUT
3	1	M12 - 1.50 x 60 HEX BOLT	HEX BOLT
4	1	1/2"	CONICAL TOOTHED WASHER
5	2	CM-SP41	.188 x 1.38 x 1.50" ROUND HOLE SPACER
6	28	7/16 WASHER	WASHER
7	2	M6 RIVET	NYLON RIVET

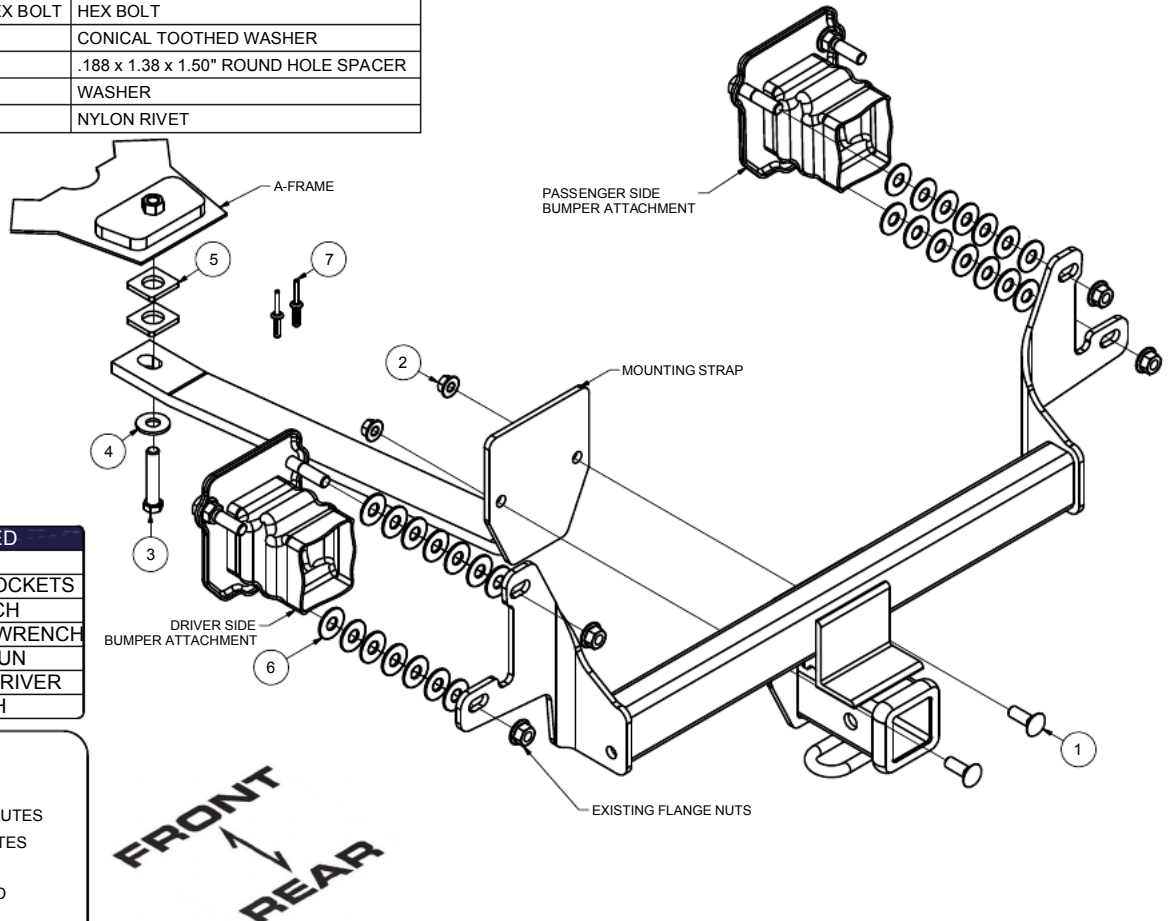
**TOOLS REQUIRED****RATCHET****8, 18, 19mm & 11/16" SOCKETS****TORQUE WRENCH****11/16" OPEN END/BOX WRENCH****PLASTIC RIVET GUN****FLAT HEAD SCREWDRIVER****CENTER PUNCH****HITCH WEIGHT: 29 LBS.****INSTALL TIME**PROFESSIONAL: 40 MINUTESNOVICE (DIY): 80 MINUTES**INSTALL NOTES:**

- NO DRILLING REQUIRED
- PART REMOVAL

INSTALLATION STEPS

1. Remove (5) fasteners and (2) nylon rivets securing rear fascia. To remove rivets push small center rod through rivet with a small punch or an equivalent tool. Pry rivets from trim and pop trim off. Unplug back up sensors. **Note:** Replacement rivets are included.
2. Remove four (4) 12mm nuts from the bumper attachments on both sides which will be reused in step # 3. Also remove a 12mm bolt from the A-frame and return it to the owner. Place (as many as needed) washers per stud between the bumper attachments and the hitch plates on both sides as shown.
3. Lift the hitch into position over studs and secure with existing flange nuts as shown.
4. Attach mounting strap to the hitch using 7/16" fasteners as shown. Place two (2) spacers between the hitch and the A-frame, and secure with 12mm bolt and conical toothed washer as shown.
5. Torque all 12mm fasteners to 82 lb-ft, and all 7/16" fasteners to 70 lb-ft.
6. Reinstall the rear fascia panel. **Note:** A plastic rivet gun is required to fasten supplied rivets.

PERIODICALLY CHECK THIS RECEIVER HITCH TO ENSURE THAT ALL FASTENERS ARE TIGHT AND THAT ALL STRUCTURAL COMPONENTS ARE SOUND.

Curt Manufacturing Inc., warrants this product to be free of defects in material and/or workmanship at the time of retail purchase by the original purchaser. If the product is found to be defective, Curt Manufacturing Inc., may repair or replace the product, at their option, when the product is returned, prepaid, with proof of purchase. Alteration to, misuse of, or improper installation of this product voids the warranty. Curt Manufacturing Inc.'s liability is limited to repair or replacement of products found to be defective, and specifically excludes liability for incidental or consequential loss or damage.