

# 13103 MERCEDES R350 / R500 / R320 CDI / R320 & R350 BlueTEC

11/26/2012

PAGE 1 of 2

GROSS LOAD CAPACITY WHEN USED AS A WEIGHT CARRYING HITCH: 3,500 LBS. TRAILER WEIGHT & 350 LBS. TONGUE WEIGHT.

**\*\*\*DO NOT EXCEED VEHICLE MANUFACTURER'S RECOMMENDED TOWING CAPACITY.\*\*\***

**WARNING: ALL NON-TRAILER LOADS APPLIED TO THIS PRODUCT MUST BE SUPPORTED BY 18050 STABILIZING STRAPS.**

**\*\* FAILURE TO PROPERLY SUPPORT NON-TRAILER LOADS WILL VOID PRODUCT WARRANTY\*\***

**HAVING INSTALLATION QUESTIONS? CALL TECHNICAL SUPPORT AT 1-877-287-8634**

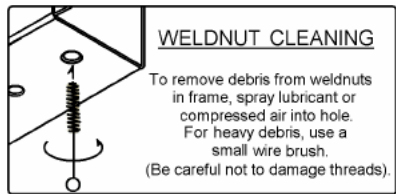
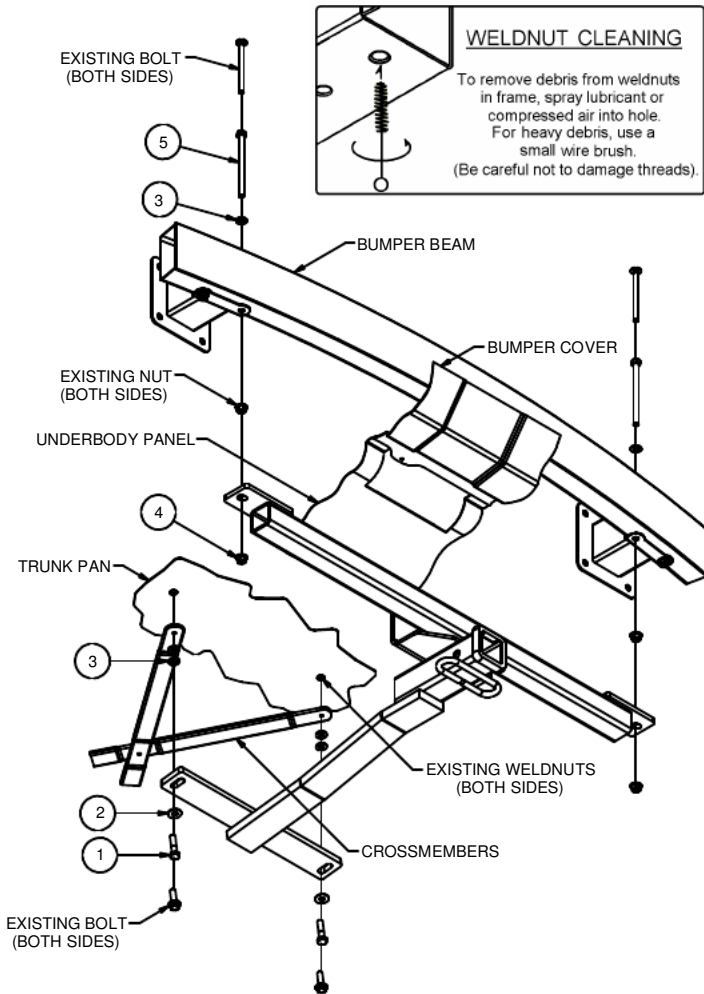

Parts List			
ITEM	QTY	PART NUMBER	DESCRIPTION
1	2	M10 - 1.5 x 45 10.9 mm	HEX BOLT
2	2	3/8"	CONICAL TOOTHED WASHER
3	6	3/8"	WASHER
4	2	ANSI B 18.2.4.4 M - M10 x 1.5	Hex Flange Nut
5	2	M10 - 1.5 x 140 10.9 HEX	HEX BOLT
6	2	7/16-14	HEX FLANGE NUT
7	2	CM-SP52	.500 x 1.25 x 2.50" ROUND HOLE SPACER
8	2	CM-SP2	.250 x .88 x 2.25" SQUARE HOLE SPACER
9	2	7/16-14 x 2	CARRIAGE BOLT

TOOLS REQUIRED	
RATCHET	
TORQUE WRENCH	
10mm SOCKET	
15mm SOCKET	
17mm SOCKET	
15mm WRENCH	
ROTARY TOOL	
SAFETY GLASSES	

## INSTALLATION ON VEHICLES WITH EXISTING CROSSMEMBERS

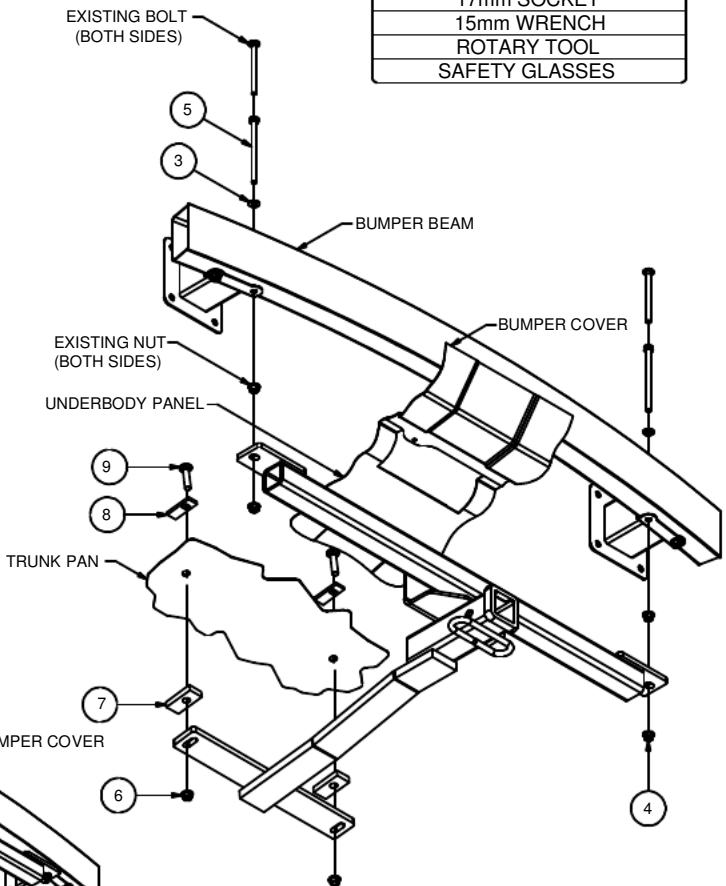

## INSTALLATION ON VEHICLES WITHOUT EXISTING CROSSMEMBERS

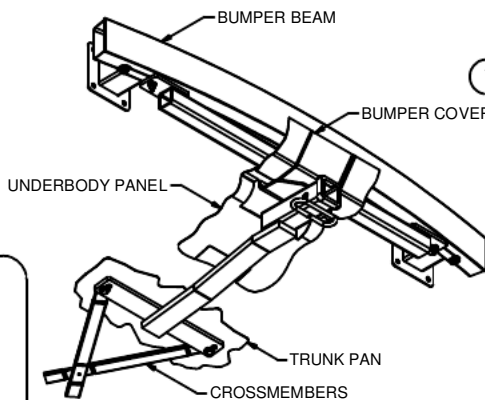

HITCH SHOWN IN PROPER POSITION

HITCH WEIGHT: 45 LBS.

INSTALL TIME

PROFESSIONAL: 45 MINUTES

NOVICE (DIY): 90 MINUTES

INSTALL NOTES:

- TRIM UNDERBODY PANEL
- REMOVE EXISTING HARDWARE

**PERIODICALLY CHECK THIS RECEIVER HITCH TO ENSURE THAT ALL FASTENERS ARE TIGHT AND THAT ALL STRUCTURAL COMPONENTS ARE SOUND.**

Curt Manufacturing LLC., warrants this product to be free of defects in material and/or workmanship at the time of retail purchase by the original purchaser. If the product is found to be defective, Curt Manufacturing LLC., may repair or replace the product, at their option, when the product is returned, prepaid, with proof of purchase. Alteration to, misuse of, or improper installation of this product voids the warranty. Curt Manufacturing LLC.'s liability is limited to repair or replacement of products found to be defective, and specifically excludes liability for incidental or consequential loss or damage.

HAVING INSTALLATION QUESTIONS? CALL TECHNICAL SUPPORT AT 1-877-287-8634

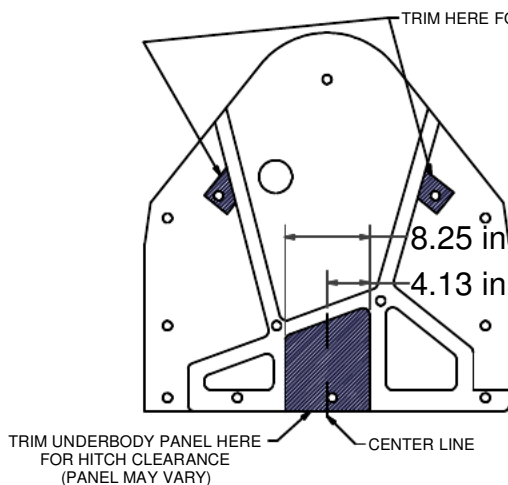

UNDERBODY PANEL TRIMMING

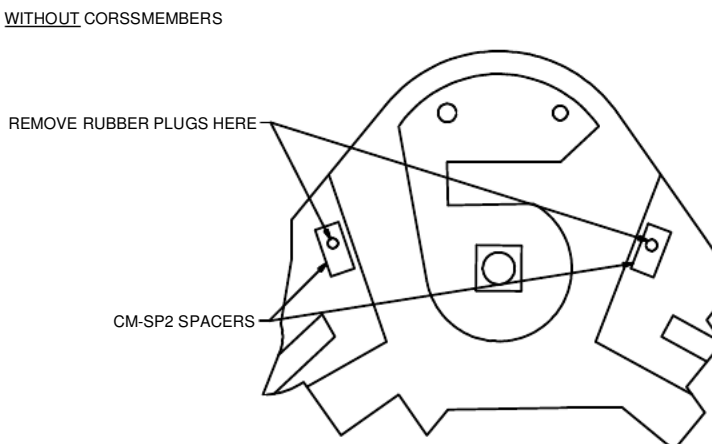

INSIDE TRUNK

## INSTALLATION STEPS

### INSTALLATION FOR VEHICLES WITH CROSSMEMBERS

1. Remove (2) M10 fasteners that secure vehicle crossmember to trunk pan.
2. Remove (4) fascia bolts. (3) bolts will be used to reattach the fascia later. (1) will not be reused and should be returned to the vehicle owner.
3. Remove nuts from underbody panel and remove the panel. Nuts and panel should be retained for reinstallation later.
4. Remove inside bumper mounting bolt and nut on driver and passenger side of vehicle. Return hardware to vehicle owner.
5. Trim underbody panel as shown in diagram. **Note:** You may need to trim the bumper cover on some models.
6. Install M10-1.5 x 140mm bolts and 3/8" flat washers through top of bumper beam, as shown.
7. Raise hitch into position and secure hitch to vehicle with M10 hex flange nuts.
8. Attach mounting strap where M10 bolts were removed in Step 1. Secure hitch with M10-1.5 x 45mm bolts and 3/8" conical toothed washers. Be sure that 3/8" flat washers are placed between the trunk pan and crossmember as shown.
9. Torque all M10 hardware to 45 lb-ft.
10. Reinstall nuts and underbody panel. Reinstall (3) fascia bolts.

### INSTALLATION FOR VEHICLES WITHOUT CROSSMEMBERS

1. Remove (4) fascia bolts. (3) bolts will be used to reattach the fascia later. (1) will not be reused and should be returned to the vehicle owner.
2. Remove nuts from underbody panel and remove the panel. Nuts and panel should be retained for reinstallation later.
3. Remove spare tire and tool kit from inside of vehicle.
4. Trim underbody panel as shown in diagram. **Note:** You may need to trim the bumper cover on some models.
5. Remove inside bumper mounting bolt and nut on driver and passenger side of vehicle. Return hardware to vehicle owner.
6. Install M10-1.5 x 140mm bolts and 3/8" flat washers through top of bumper beam, as shown.
7. Raise hitch and underbody panel into position and secure hitch to vehicle with M10 hex flange nuts.
8. Remove rubber plugs from existing holes and secure hitch mounting bracket to vehicle trunk pan with supplied 7/16" carriage bolts, 7/16" hex flange nuts and CM-SP2 spacers. Be sure CM-SP52 spacers are placed between the trunk pan and hitch as shown and that CM-SP2 spacers are oriented as shown.
9. Torque all M10 hardware to 45 lb-ft and 7/16" hardware to 70 lb-ft.
10. Use silicone sealant to seal hardware installed through trunk pan.
11. Reinstall nuts and underbody panel. Reinstall (3) fascia bolts Return spare tire and tool kit to vehicle.

**PERIODICALLY CHECK THIS RECEIVER HITCH TO ENSURE THAT ALL FASTENERS ARE TIGHT AND THAT ALL STRUCTURAL COMPONENTS ARE SOUND.**