



Safety glasses should be worn at all times while installing this product.

YEARS: 2017-CURRENT

MAKE: SUBARU

MODEL: IMPREZA

STYLE: 5-DOOR

WARNING: NEVER EXCEED YOUR VEHICLE MANUFACTURER'S RECOMMENDED TOWING CAPACITY
 For more information log onto www.curtmfg.com & for helpful towing tips log onto www.hitchinfo.com

WEIGHT CARRYING:
 TRAILER WEIGHT: 2,000 LBS.
 TONGUE WEIGHT: 200 LBS.

WARNING:
 WE RECOMMEND THE USE OF 18050 STABILIZING STRAPS FOR ALL NON-TRAILER (WHEEL-LESS) LOADS. PLEASE SEE THE CURT CATALOG OR VISIT US ONLINE AT WWW.CURTMFG.COM FOR FURTHER INFORMATION.

PRO INSTALL TIME: 30 MIN.
NOVICE INSTALL TIME: 60 MIN.

IF YOU ARE HESITANT TO UNDERTAKE THIS TASK ON YOUR OWN, CONTACT AN AUTHORIZED CURT INSTALLER FOR ADDITIONAL ASSISTANCE.

INSTALLATION REQUIRES:

DIE GRINDER	SOCKET	RATCHET
SAFETY GLASSES	TORQUE WRENCH	

INSTALLATION TIPS:

- BEFORE YOU BEGIN INSTALLATION, READ ALL INSTRUCTIONS THOROUGHLY.
- TO EASE INSTALLATION, 2 PEOPLE MAY BE REQUIRED.
- USING PROPER TOOLS WILL GREATLY IMPROVE THE QUALITY OF THE INSTALL AND REDUCE THE TIME REQUIRED.
- NEED HELP OR HAVE SOME QUESTIONS? CALL TECHNICAL SUPPORT AT 800.798.0813

LEVEL OF DIFFICULTY: EASY

EASY	MODERATE	CHALLENGING
FISHWIRE (2) FASTENERS		
ENLARGE ACCESS HOLES FOR SPACERS AND BOLTS		
REMOVE (4) RUBBER PLUGS		
REVERSE FISHWIRE (2) FASTENERS		

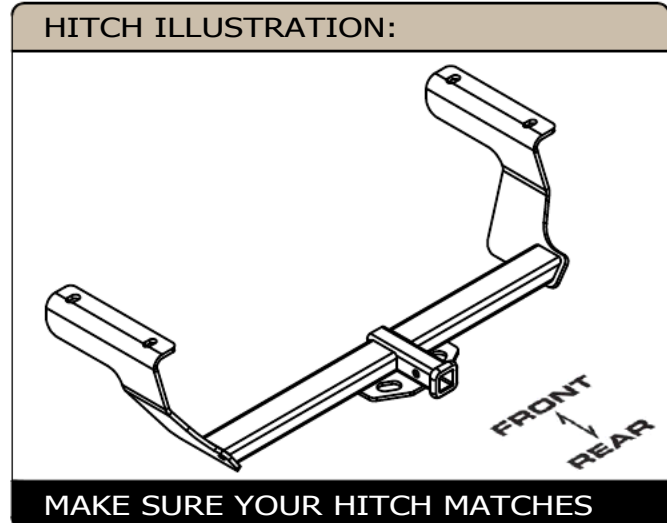

SCAN FOR MORE INFO

PERIODICALLY CHECK THIS RECEIVER HITCH TO ENSURE ALL FASTENERS ARE TIGHT AND ALL STRUCTURAL COMPONENTS ARE SOUND
 CURT Manufacturing LLC. warrants this product to be free of defects in material and/or workmanship at the time of retail purchase by the original purchaser. If the product is found to be defective, CURT Manufacturing LLC. may repair or replace the product at their option, when the product is returned, prepaid, with proof of purchase. Alteration to, misuse of, or improper installation of this product voids the warranty. CURT Manufacturing LLC.'s liability is limited to repair or replacement of products found to be defective, and specifically excludes liability for incidental or consequential loss or damage.
 For more information log onto www.curtmfg.com, & for helpful towing tips log onto www.hitchinfo.com
 This product complies with safety specifications and requirements for connecting devices and towing systems of the state of New York, V.E.S.C.Regulation V-5 and SAE J684.

INSTALLATION WALKTHROUGH:

Parts List			
ITEM	QTY	PART NUMBER	DESCRIPTION
1	2	1/2-13 x 1 1/2	CARRIAGE BOLT
2	2	CM-SP6	.250 x 1.00 x 3.00" SQUARE HOLE SPACER
3	2	7/16-14 x 1 1/2	CARRIAGE BOLT
4	2	CM-SP11	.250 x 1.00 x 2.50" SQUARE HOLE SPACER
5	2	CM-SP16	.250 x 1.50 x 2.00" ROUND HOLE SPACER
6	2	HFN 1213	HEX FLANGE NUT
7	2	7/16-14	HEX FLANGE NUT
8	2	7_16 FISHWIRE	7/16" FISHWIRE
9	2	1_2 FISHWIRE	1/2" FISHWIRE

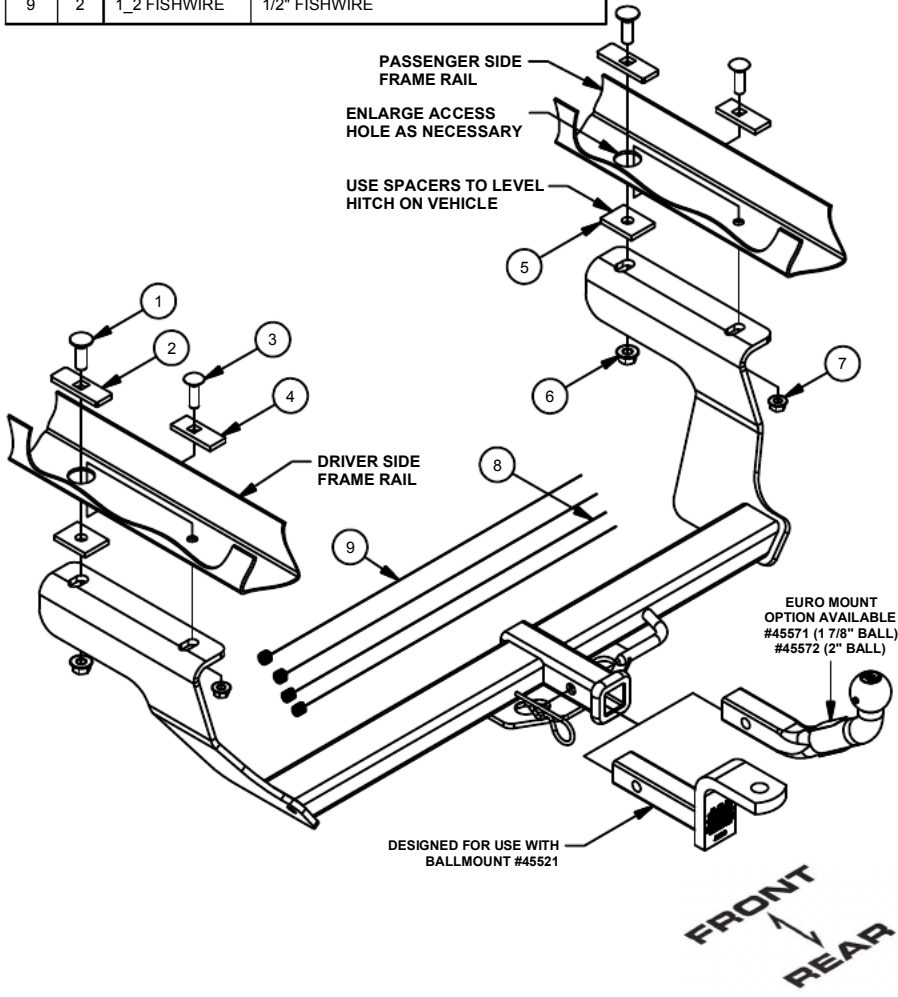

1) Remove the (4) plugs in the frame rails and return to vehicle owner (leave center plugs in).



2) Fishwire 7/16" carriage bolts and CM-SP11 spacers into position first and reverse fishwire 1/2" carriage bolts and CM-SP6 spacers into position afterward. (enlarge access hole as necessary)

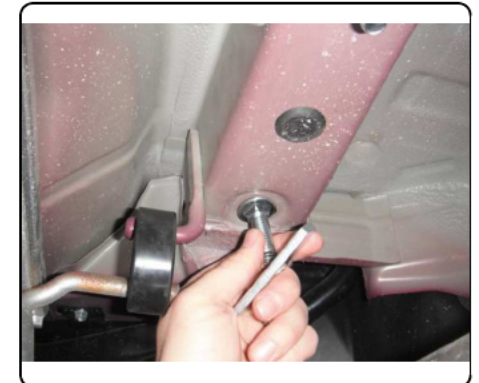

INSTALLATION WALKTHROUGH:

- 3) Raise hitch to the frame aligning the holes in the hitch with the bolts. Use 1.50" x 2.00" spacers to level hitch as necessary. Install remaining supplied hardware, as shown on page 2.
Note: Be careful not to push the bolts into the frame.



- 4) Torque all 7/16" fasteners to 70 lb-ft, and all 1/2" fasteners to 110 lb-ft.

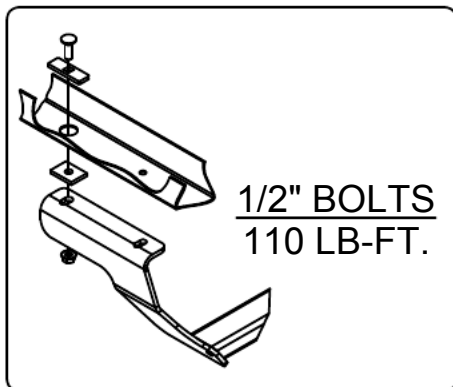
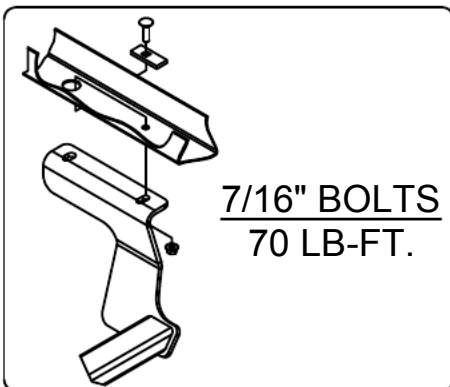

11465

SUBARU IMPREZA 5-DOOR

1/30/2017

GROSS LOAD CAPACITY WHEN USED AS A WEIGHT CARRYING HITCH: 2,000 LBS. TRAILER WEIGHT & 200 LBS. TONGUE WEIGHT. WARNING: ALL NON-TRAILER LOADS APPLIED TO THIS PRODUCT MUST BE SUPPORTED BY 18050 STABILIZING STRAPS.



WARNING: ** FAILURE TO PROPERLY SUPPORT NON-TRAILER LOADS WILL VOID PRODUCT WARRANTY **

WARNING: *** DO NOT EXCEED VEHICLE MANUFACTURER'S RECOMMENDED TOWING CAPACITY ***

FOR MORE INFORMATION LOG ONTO WWW.CURTMFG.COM & FOR HELPFUL TOWING TIPS LOG ONTO WWW.HITCHINFO.COM HAVING INSTALLATION QUESTIONS? CALL TECHNICAL SUPPORT AT 1-877-287-8634



Parts List			
ITEM	QTY	PART NUMBER	DESCRIPTION
1	2	1/2-13 x 1 1/2	CARRIAGE BOLT
2	2	CM-SP6	.250 x 1.00 x 3.00" SQUARE HOLE SPACER
3	2	7/16-14 x 1 1/2	CARRIAGE BOLT
4	2	CM-SP11	.250 x 1.00 x 2.50" SQUARE HOLE SPACER
5	2	CM-SP16	.250 x 1.50 x 2.00" ROUND HOLE SPACER
6	2	HFN 1213	HEX FLANGE NUT
7	2	7/16-14	HEX FLANGE NUT
8	2	7_16 FISHWIRE	7/16" FISHWIRE
9	2	1_2 FISHWIRE	1/2" FISHWIRE

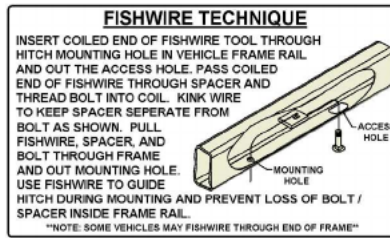

- TOOLS REQUIRED**
- RATCHET
 - 3/4" & 11/16" SOCKETS
 - DIE GRINDER
 - TORQUE WRENCH
 - SAFETY GLASSES

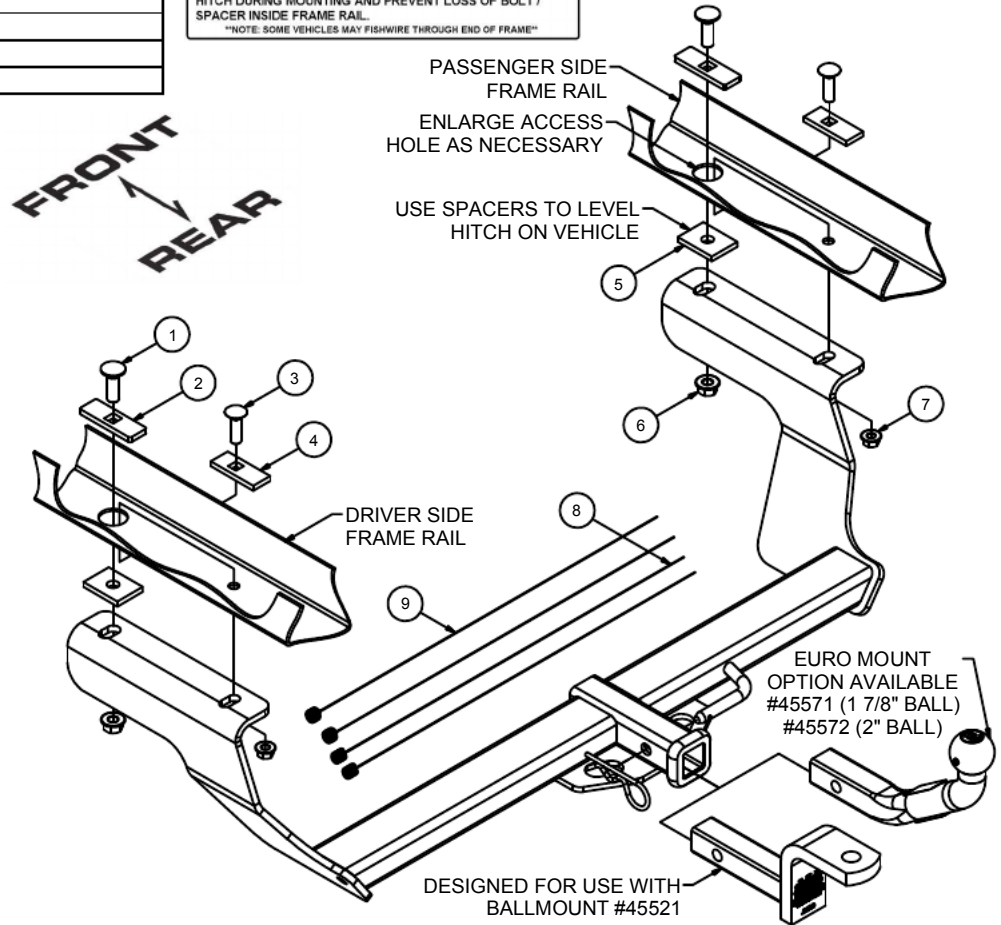
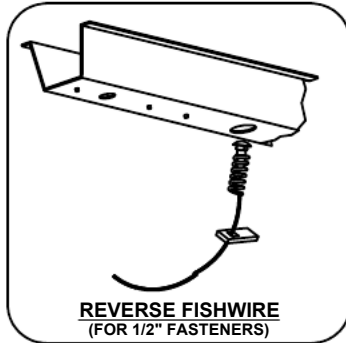

HITCH WEIGHT: 30 LBS.
 INSTALL TIME
 PROFESSIONAL: 30 MINUTES
 NOVICE (DIY): 60 MINUTES
 INSTALL NOTES:
 - NO DRILLING
 - HOLE ENLARGEMENT REQUIRED

INSTALLATION STEPS

- 1) Remove the (4) plugs in the frame rails and return to vehicle owner (leave center plugs in).
- 2) Fishwire 7/16" carriage bolts and CM-SP11 spacers into position first and reverse fishwire the 1/2" carriage bolts and CM-SP6 spacers into position afterward. (enlarge access hole as necessary)
- 3) Raise hitch to the frame aligning the holes in the hitch with the bolts. Use 1.50" x 2.00" spacers to level hitch as necessary. Install remaining supplied hardware, as shown above.

NOTE: Be careful not to push the bolts in the frame.

- 4) Torque all 7/16" fasteners to 70 lb-ft, and all 1/2" fasteners to 110 lb-ft.



Scan for more information

PERIODICALLY CHECK THIS RECEIVER HITCH TO ENSURE THAT ALL FASTENERS ARE TIGHT AND THAT ALL STRUCTURAL COMPONENTS ARE SOUND.

CURT Manufacturing LLC., warrants this product to be free of defects in material and/or workmanship at the time of retail purchase by the original purchaser. If the product is found to be defective, CURT Manufacturing LLC., may repair or replace the product, at their option, when the product is returned, prepaid, with proof of purchase. Alteration to, misuse of, or improper installation of this product voids the warranty. CURT Manufacturing LLC.'s liability is limited to repair or replacement of products found to be defective, and specifically excludes liability for incidental or consequential loss or damage.

This product complies with safety specifications and requirements for connecting devices and towing systems of the state of New York, V.E.S.C.Regulation V-5 and SAE J684.