

13035

## 85-05 CHEVY/GMC ASTRO &amp; SAFARI

7/16/2012

EXCEPT 16" SPARE

GROSS LOAD CAPACITY WHEN USED AS A WEIGHT CARRYING HITCH: 4,000 LBS. TRAILER WEIGHT & 400 LBS. TONGUE WEIGHT.  
 GROSS LOAD CAPACITY WHEN USED AS A WEIGHT DISTRIBUTION HITCH: 6,000 LBS. TRAILER WEIGHT & 600 LBS. TONGUE WEIGHT

\*\*\*DO NOT EXCEED VEHICLE MANUFACTURER'S RECOMMENDED TOWING CAPACITY.\*\*\*

HAVING INSTALLATION QUESTIONS? CALL TECHNICAL SUPPORT AT 1-877-287-8634

Parts List			
ITEM	QTY	PART NUMBER	DESCRIPTION
1	1	1/2"	FISHWIRE TOOL
2	8	7/16-14	HEX FLANGE NUT
3	2	M10 - 1.5 x 40mm	HEX BOLT
4	2	7/16 LOCK WASHER	HELICAL LOCK WASHER
5	2	7/16 WASHER	WASHER
6	2	HFN 1213	HEX FLANGE NUT
7	2	CM-SP1	.250 x 1.50 x 2.00" SQUARE HOLE SPACER
8	2	1/2-13 x 1 3/4	CARRIAGE BOLT
9	8	7/16-14 x 1 1/4	CARRIAGE BOLT

## FISHWIRE TECHNIQUE

INSERT COILED END OF FISHWIRE TOOL THROUGH HITCH MOUNTING HOLE IN VEHICLE FRAME RAIL AND OUT THE ACCESS HOLE. PASS COILED END OF FISHWIRE THROUGH SPACER AND THREAD BOLT INTO COIL. KINK WIRE TO KEEP SPACER SEPERATE FROM BOLT AS SHOWN. PULL FISHWIRE, SPACER, AND BOLT THROUGH FRAME AND OUT MOUNTING HOLE. USE FISHWIRE TO GUIDE HITCH DURING MOUNTING AND PREVENT LOSS OF BOLT / SPACER INSIDE FRAME RAIL.

\*\*NOTE: SOME VEHICLES MAY FISHWIRE THROUGH END OF FRAME\*\*

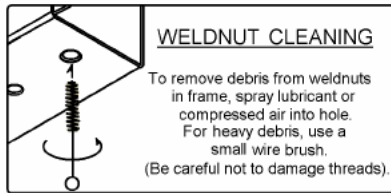

## WELDNUT CLEANING

To remove debris from weldnuts in frame, spray lubricant or compressed air into hole. For heavy debris, use a small wire brush. (Be careful not to damage threads).

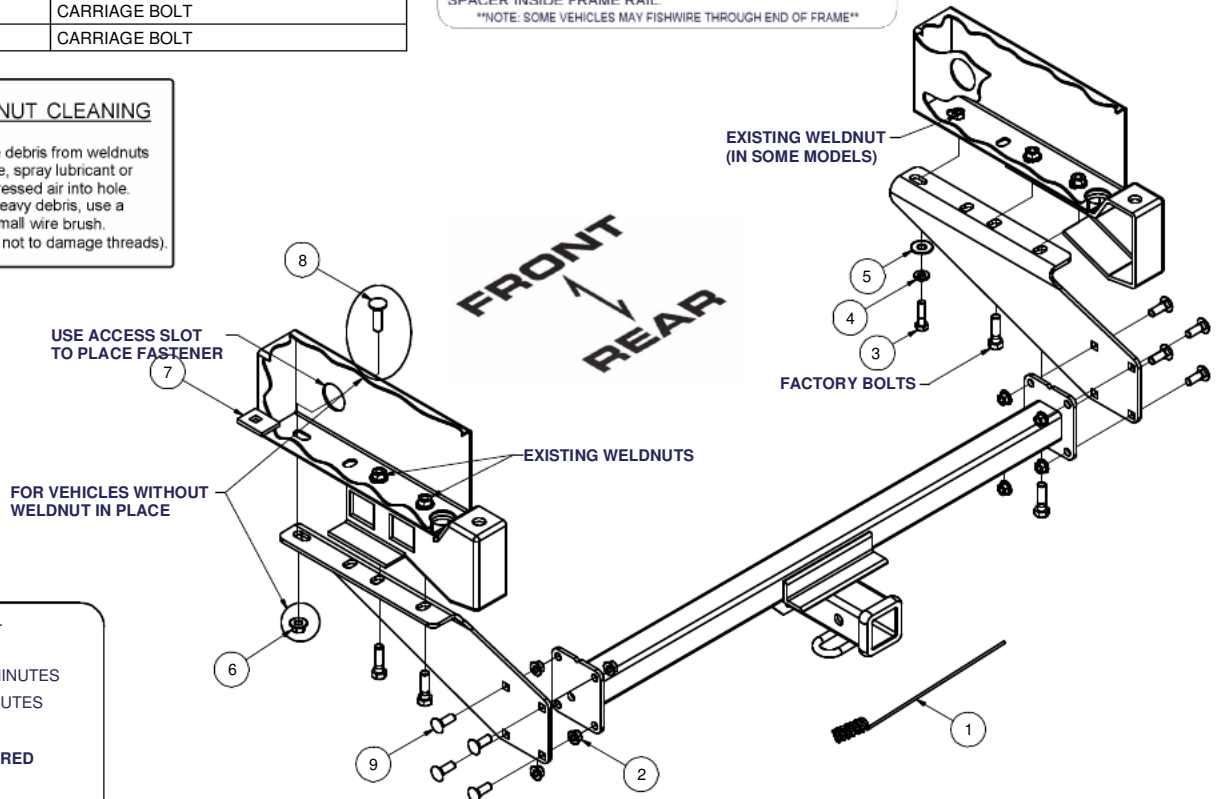

HITCH WEIGHT: 39 LBS.

## INSTALL TIME

PROFESSIONAL: 45 MINUTES

NOVICE (DIY): 90 MINUTES

## INSTALL NOTES:

- NO DRILLING REQUIRED
- REMOVE BUMPER BRACKET BOLTS

## INSTALLATION STEPS

- 1) Remove bumper bracket bolts and set aside for later install directions.
- 2) Position end plate between bumper bracket and frame. Align the holes of the bumper bracket with the holes of the hitch and loosely reinstall factory bolts.
- 3) **Early models:** Using 1/2" carriage bolts and square hole spacers provided, pass one of each through the large hole in frame under the bumper bracket into the hole in the end plate.  
**Late models :** With weldnut at furthest hole, from rear bumper, in frame install 10mm bolt with 7/16" lockwasher and flatwasher.
- 4) Position receiver cross-tube assembly between the end plates. Install 7/16" bolts in end plates and tighten with 7/16" hex flange nuts.
- 5) First: Torque 7/16" fasteners to 70 lb-ft.  
 Then: Torque all remaining 10mm bolts to 45 lb-ft., 1/2" bolts to 110 lb-ft.

**PERIODICALLY CHECK THIS RECEIVER HITCH TO ENSURE THAT ALL FASTENERS ARE TIGHT AND THAT ALL STRUCTURAL COMPONENTS ARE SOUND.**

Curt Manufacturing Inc., warrants this product to be free of defects in material and/or workmanship at the time of retail purchase by the original purchaser. If the product is found to be defective, Curt Manufacturing Inc., may repair or replace the product, at their option, when the product is returned, prepaid, with proof of purchase. Alteration to, misuse of, or improper installation of this product voids the warranty. Curt Manufacturing Inc.'s liability is limited to repair or replacement of products found to be defective, and specifically excludes liability for incidental or consequential loss or damage.