



Safety glasses should be worn at all times while installing this product.

YEARS: 2011-CURRENT

MAKE: JEEP

MODEL: PATRIOT & COMPASS

STYLE: SUV

WARNING: NEVER EXCEED YOUR VEHICLE MANUFACTURER'S RECOMMENDED TOWING CAPACITY





WEIGHT CARRYING:
TRAILER WEIGHT: 3,500 LBS.
TONGUE WEIGHT: 300 LBS.

WARNING:
WE RECOMMEND THE USE OF 18050 STABILIZING STRAPS FOR ALL NON-TRAILER (WHEEL-LESS) LOADS. PLEASE SEE THE CURT CATALOG OR VISIT US ONLINE AT WWW.CURTMFG.COM FOR FURTHER INFORMATION.

INSTALLATION TIME: 35 MIN.

THE INSTALL TIME LISTED IS FOR PROFESSIONAL INSTALLERS. IF YOU ARE HESITANT TO UNDERTAKE THIS TASK ON YOUR OWN, CONTACT AN AUTHORIZED CURT INSTALLER FOR ADDITIONAL ASSISTANCE.



INSTALLATION REQUIRES:

 RATCHET	 5/8" 3/4" 7mm 11mm SOCKET	 TORQUE WRENCH
 TAPE MEASURE	 SAFETY GLASSES	

INSTALLATION TIPS:

- BEFORE YOU BEGIN INSTALLATION, READ ALL INSTRUCTIONS THOROUGHLY.
- TO EASE INSTALLATION, 2 PEOPLE MAY BE REQUIRED.
- USING PROPER TOOLS WILL GREATLY IMPROVE THE QUALITY OF THE INSTALL AND REDUCE THE TIME REQUIRED.
- NEED HELP OR HAVE SOME QUESTIONS? CALL TECHNICAL SUPPORT AT 800.798.0813

LEVEL OF DIFFICULTY: HARD

EASY	MODERATE	HARD
	LOWER EXHAUST BY REMOVING (3) RUBBER ISOLATORS	
	FASCIA TRIMMING REQUIRED	

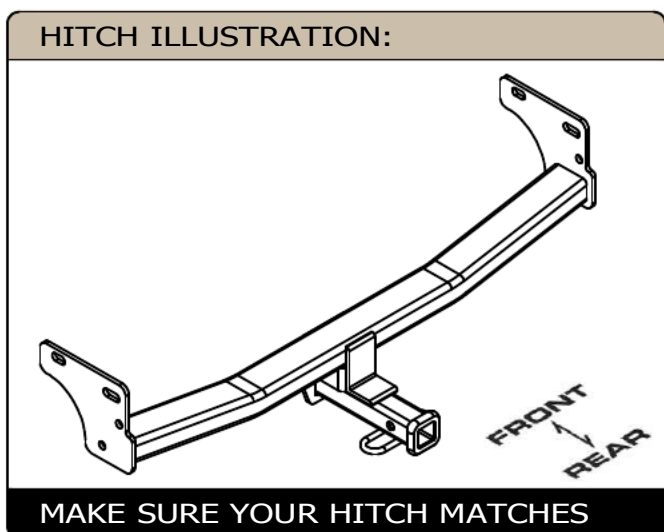

PERIODICALLY CHECK THIS RECEIVER HITCH TO ENSURE ALL FASTENERS ARE TIGHT AND ALL STRUCTURAL COMPONENTS ARE SOUND

CURT Manufacturing Inc. warrants this product to be free of defects in material and/or workmanship at the time of retail purchase by the original purchaser. If the product is found to be defective, Curt Manufacturing Inc. may repair or replace the product at their option, when the product is returned, prepaid, with proof of purchase. Alteration to, misuse of, or improper installation of this product voids the warranty. Curt Manufacturing Inc.'s liability is limited to repair or replacement of products found to be defective, and specifically excludes liability for incidental or consequential loss or damage.

INSTALLATION WALKTHROUGH:

Parts List			
ITEM	QTY	PART NUMBER	DESCRIPTION
1	4	1_2 - 13 x 4	HEX BOLT
2	4	FW12	FW, 12, ZP
3	4	HFN 1213	HEX FLANGE NUT

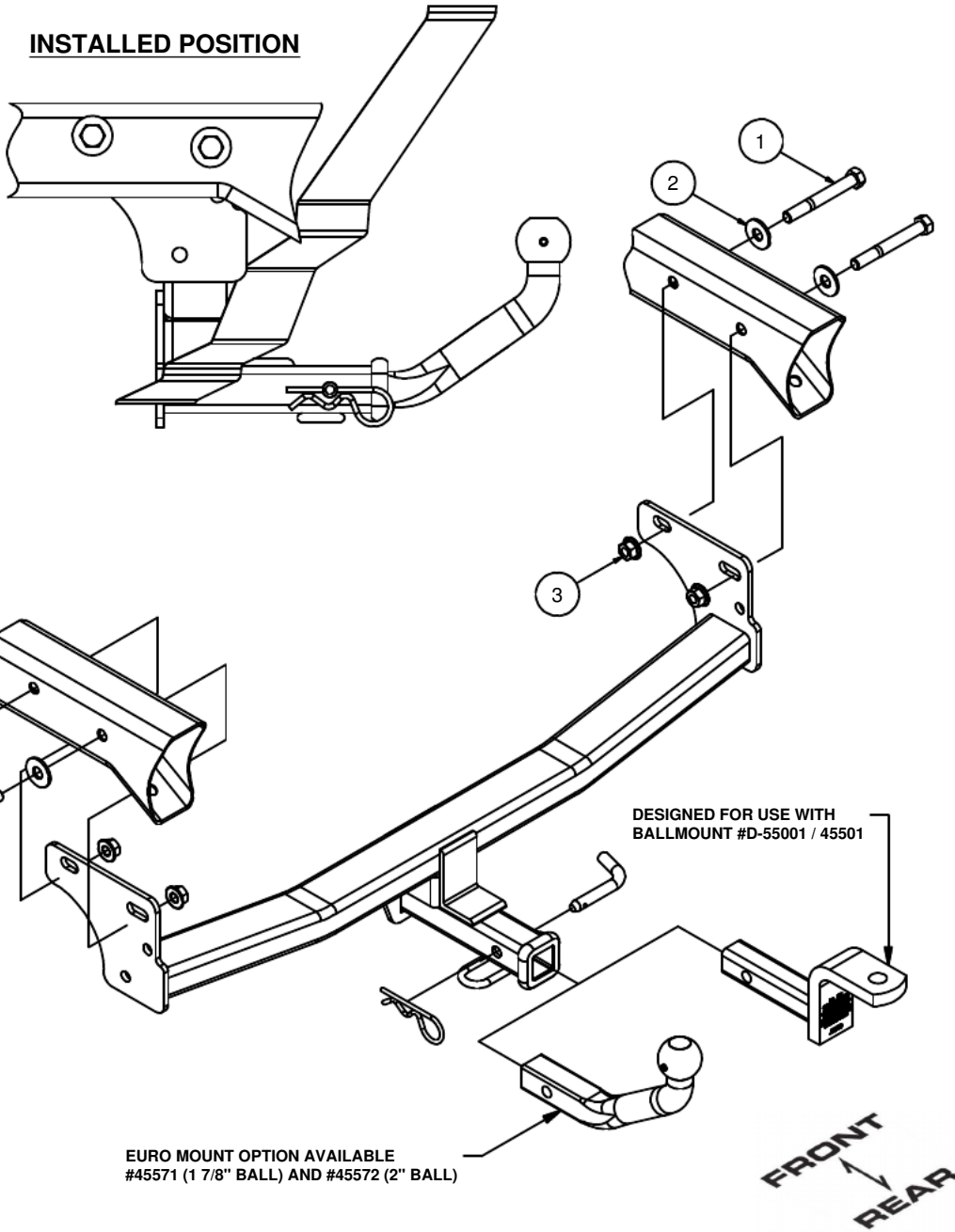
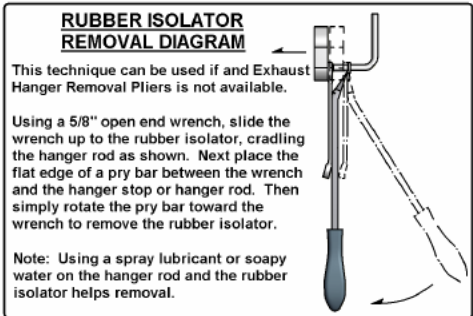
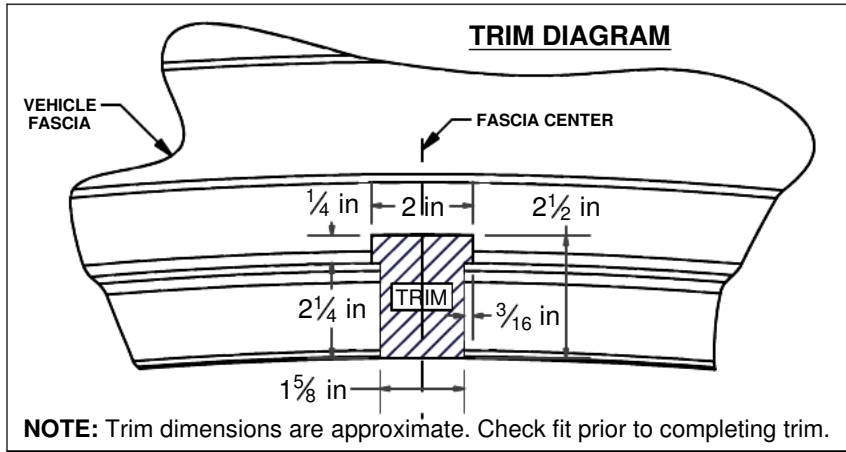

INSTALLATION WALKTHROUGH:

1. Temporarily remove (4) plastic fasteners and (4) hex screws from fascia.

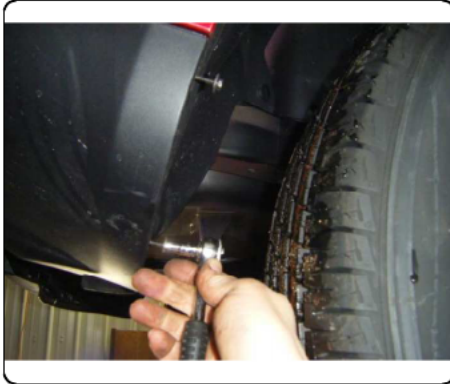

2. Lower exhaust by removing (3) rubber isolators. See RUBBER ISOLATOR REMOVAL DIAGRAM on page 2. (Note: Support exhaust to avoid possible damage.)



3. Temporarily remove heat shield by removing (4) nuts. (Note: If tow loop is present remove and return to vehicle owner.)



4. Insert 4" hex bolts with washers into the frame rails from the outside. Raise the hitch into position between the frame rails. Push front bolts through mounting plates and loosely install 1/2" flange nuts.



INSTALLATION WALKTHROUGH:

5. Rotate hitch up so that it is touching fascia and mark where to trim.



6. Trim fascia. See TRIM DIAGRAM on page 2.
(**Note:** Check fit prior to completing trim)

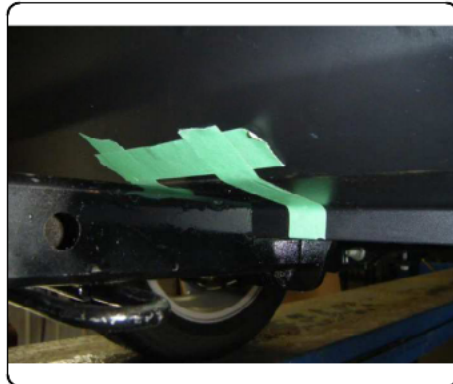

7. Install remaining 1/2" bolts and secure hitch with hex flange nuts. Torque all 1/2" fasteners to 110 ft-lbs.



8. Reinstall heat shield, fasteners, and exhaust.



12057

JEEP PATRIOT & COMPASS

10/5/2012

PAGE 1 of 2

GROSS LOAD CAPACITY WHEN USED AS A WEIGHT CARRYING HITCH: 3,500 LBS. TRAILER WEIGHT & 300 LBS. TONGUE WEIGHT.

*****DO NOT EXCEED VEHICLE MANUFACTURER'S RECOMMENDED TOWING CAPACITY.*****

WARNING: ALL NON-TRAILER LOADS APPLIED TO THIS PRODUCT MUST BE SUPPORTED BY 18050 STABILIZING STRAPS.

**** FAILURE TO PROPERLY SUPPORT NON-TRAILER LOADS WILL VOID PRODUCT WARRANTY****

HAVING INSTALLATION QUESTIONS? CALL TECHNICAL SUPPORT AT 1-877-287-8634

Parts List			
ITEM	QTY	PART NUMBER	DESCRIPTION
1	4	1_2 - 13 x 4	HEX BOLT
2	4	FW12	FW, 12, ZP
3	4	HFN 1213	HEX FLANGE NUT

TOOLS REQUIRED
RATCHET
5/8", 3/4", 7mm & 11mm SOCKET
TAPE MEASURE
TORQUE WRENCH

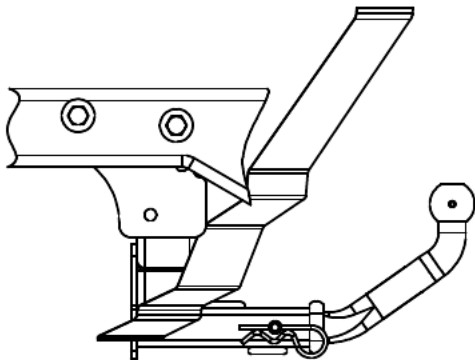

INSTALLED POSITION

FRONT
↕
REAR

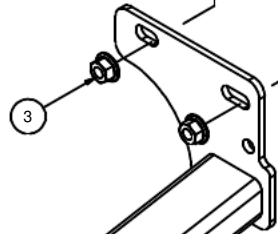
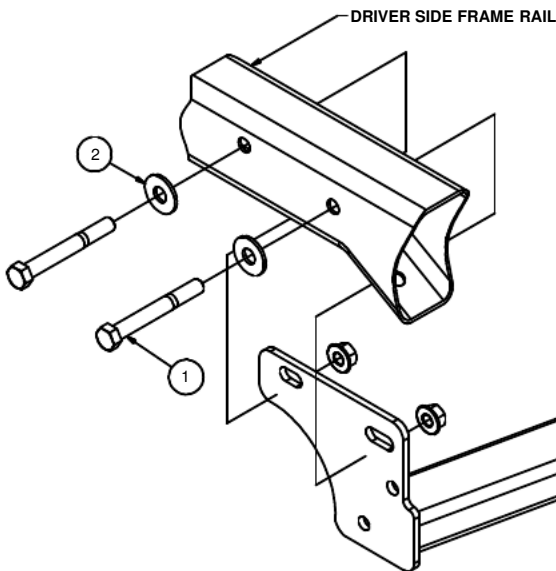
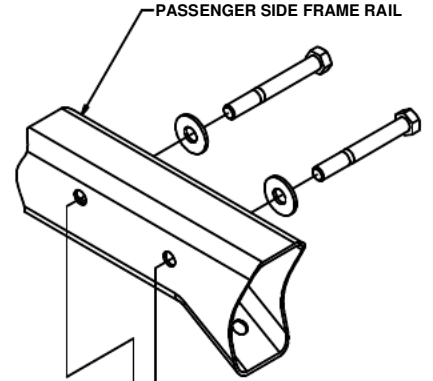

EURO MOUNT OPTION AVAILABLE
#45571 (1 7/8" BALL) AND #45572 (2" BALL)

DESIGNED FOR USE WITH
BALLMOUNT #D-55001 / 45501

HITCH WEIGHT: 30 LBS.
 INSTALL TIME
 PROFESSIONAL: 30 MINUTES
 NOVICE (DIY): 60 MINUTES
 INSTALL NOTES:
 - NO DRILLING REQUIRED
 - FASCIA TRIMMING REQUIRED
 - LOWER EXHAUST

PERIODICALLY CHECK THIS RECEIVER HITCH TO ENSURE THAT ALL FASTENERS ARE TIGHT AND THAT ALL STRUCTURAL COMPONENTS ARE SOUND.

Curt Manufacturing Inc., warrants this product to be free of defects in material and/or workmanship at the time of retail purchase by the original purchaser. If the product is found to be defective, Curt Manufacturing Inc., may repair or replace the product, at their option, when the product is returned, prepaid, with proof of purchase. Alteration to, misuse of, or improper installation of this product voids the warranty. Curt Manufacturing Inc.'s liability is limited to repair or replacement of products found to be defective, and specifically excludes liability for incidental or consequential loss or damage.

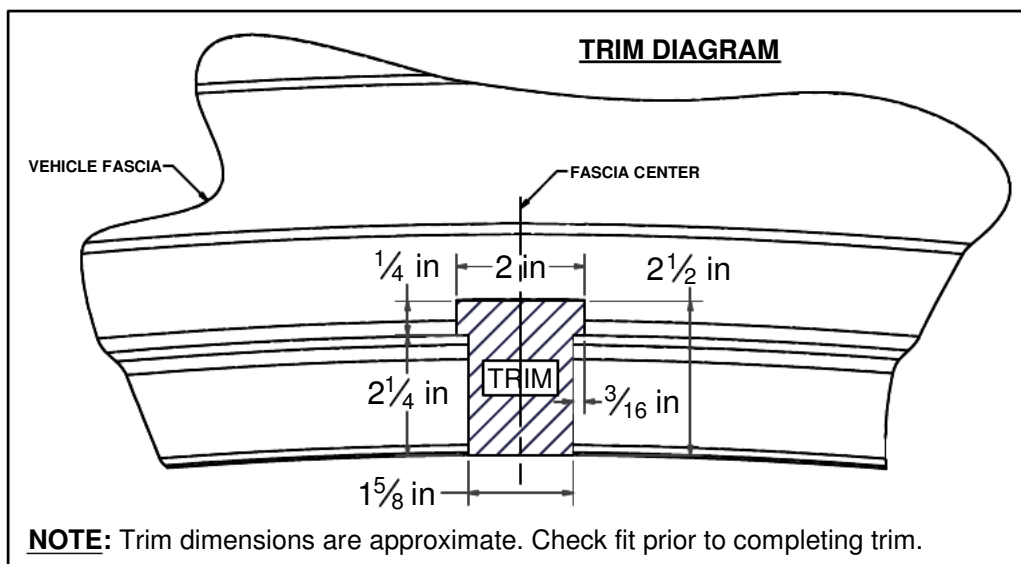
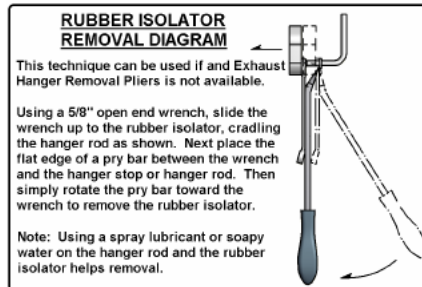

INSTALLATION STEPS

1. Temporarily remove (4) plastic fasteners and (4) hex screws from fascia.
2. Lower exhaust by removing (3) rubber isolators. See RUBBER ISOLATOR REMOVAL DIAGRAM above. (**Note:** Support exhaust to avoid possible damage.)
3. Temporarily remove heat shield by removing (4) nuts. (**Note:** If tow loop is present remove and return to vehicle owner.)
4. Insert 4" hex bolts with washers into the frame rails from the outside. Raise the hitch into position between the frame rails. Push front bolts through mounting plates and loosely install 1/2" flange nuts.
5. Rotate hitch up so that it is touching fascia and mark where to trim.
6. Trim fascia. See TRIM DIAGRAM above. (**Note:** Check fit prior to completing trim.)
7. Install remaining 1/2" fasteners and secure hitch with hex flange nuts.
8. Torque all 1/2" fasteners to 110 lb-ft.
9. Reinstall heat shield, fasteners, and exhaust.

PERIODICALLY CHECK THIS RECEIVER HITCH TO ENSURE THAT ALL FASTENERS ARE TIGHT AND THAT ALL STRUCTURAL COMPONENTS ARE SOUND.