

12137**84-01 JEEP CHEROKEE / JEEP WAGONEER**

10/15/2012

GROSS LOAD CAPACITY WHEN USED AS A WEIGHT CARRYING HITCH: 3,500 LBS. TRAILER WEIGHT & 350 LBS. TONGUE WEIGHT.

*****DO NOT EXCEED VEHICLE MANUFACTURER'S RECOMMENDED TOWING CAPACITY.*******WARNING: ALL NON-TRAILER LOADS APPLIED TO THIS PRODUCT MUST BE SUPPORTED BY AUXILIARY STABILIZING STRAPS.****** FAILURE TO PROPERLY SUPPORT NON-TRAILER LOADS WILL VOID PRODUCT WARRANTY****

HAVING INSTALLATION QUESTIONS? CALL TECHNICAL SUPPORT AT 1-877-287-8634

Parts List			
ITEM	QTY	PART NUMBER	DESCRIPTION
1	8	FW12	FW, 12, ZP
2	2	1/2-13 x 1 3/4	HEX BOLT
3	8	HFN 1213	HEX FLANGE NUT
4	8	1/2"	LOCK WASHER
5	8	M12-1.75 x 40mm	HEX BOLT
6	6	CM-SP1	.250 x 1.50 x 2.00" SQUARE HOLE SPACER
7	2	CM-SP8	.188 x 1.25 x 1.50" ROUND HOLE SPACER
8	6	1/2-13 x 1 3/4	CARRIAGE BOLT
9	1	1_2 FISHWIRE	1/2" FISHWIRE

FISHWIRE TECHNIQUE

INSERT COILED END OF FISHWIRE TOOL THROUGH HITCH MOUNTING HOLE IN VEHICLE FRAME RAIL AND OUT THE ACCESS HOLE. PASS COILED END OF FISHWIRE THROUGH SPACER AND THREAD BOLT INTO COIL. KINK WIRE TO KEEP SPACER SEPERATE FROM BOLT AS SHOWN. PULL FISHWIRE, SPACER, AND BOLT THROUGH FRAME AND OUT MOUNTING HOLE. USE FISHWIRE TO GUIDE HITCH DURING MOUNTING AND PREVENT LOSS OF BOLT / SPACER INSIDE FRAME RAIL.

NOTE: SOME VEHICLES MAY FISHWIRE THROUGH END OF FRAME

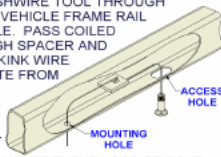

FRONT
↑
REAR

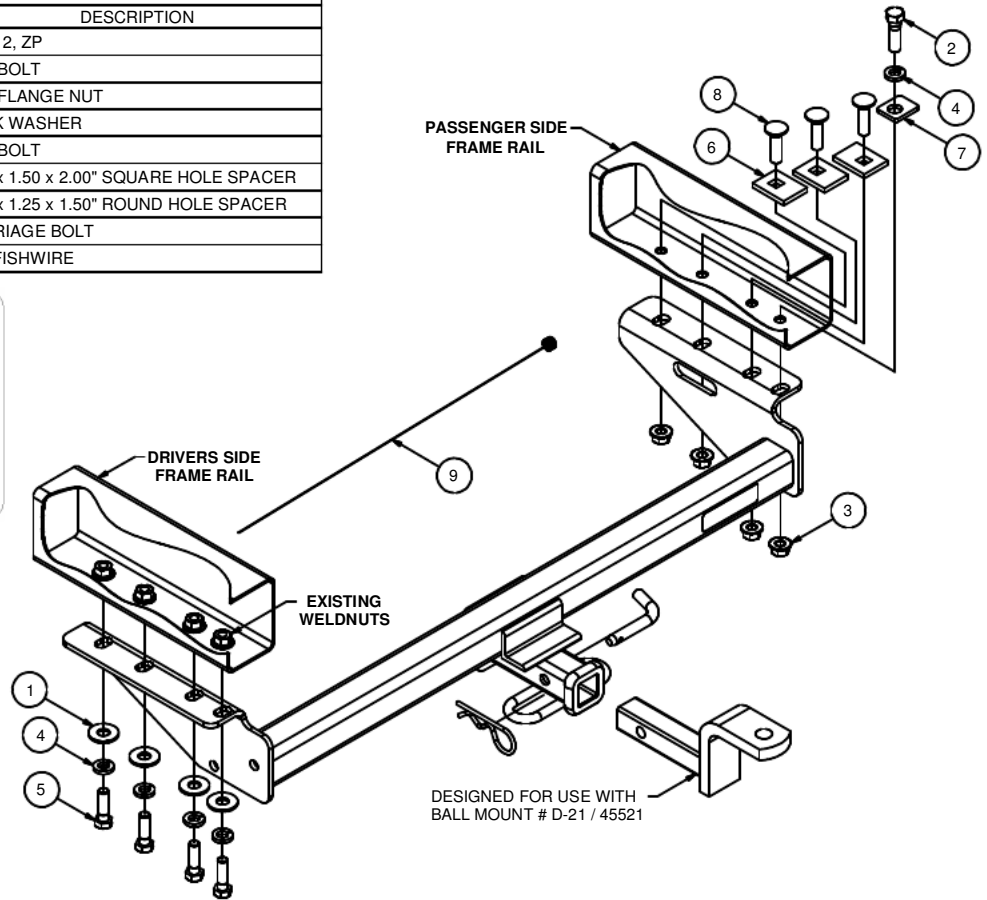
HITCH WEIGHT: 58 LBS.INSTALL TIME: 45 MINUTES

INSTALL NOTES:

INSTALLATION STEPS

OPTION A (For vehicles equipped with frame mounted, closed sided, steel skid shield.)

- 1) Remove the rear skid shield mounting bolt and loosen the forward mounting bolt on each side so that the skid shield is lowered about 1/4".
- 2) Raise the hitch into position, putting the mounting plate flange between the frame and the skid shield.
- 3) Install four M12 bolts and lock washers on each side. (Both sides will look like the drivers side frame rail in illustration.) The attachment hole closest to the front of the vehicle should have a flat washer between the hitch mounting plate and the vehicle frame.
- 4) Remove the forward skid shield mounting bolts and place two 1/2" flat washers between the frame and the skid shield. With the washers in position re-install the M12 fastener.

OPTION B (For vehicles with frame mounted tow hook on the driver side.)

- 1) Remove the tow hook and tow hook bracket, mount the driver side of the hitch using M12 bolts as shown.
- 2) Install 1/2" hardware and spacers as shown on passenger side.

OPTION C (For vehicles without frame mounted tow hook or steel skid shield.)

- 1) Fishwire the square hole spacers and the carriage bolts through the end of the frame and into the existing holes as shown. Note: Removal of the bumper will ease the fishwire process.
- 2) See passenger side of illustration for proper orientation of spacers.
- 3) Install all 1/2" flangenuts as shown on passenger side of the illustration.

NOTE: Torque all 1/2" hardware to 110 ft-lbs. Torque all M12 hardware to 86 ft-lbs.

PERIODICALLY CHECK THIS RECEIVER HITCH TO ENSURE THAT ALL FASTENERS ARE TIGHT AND THAT ALL STRUCTURAL COMPONENTS ARE SOUND.

Curt Manufacturing Inc., warrants this product to be free of defects in material and/or workmanship at the time of retail purchase by the original purchaser. If the product is found to be defective, Curt Manufacturing Inc., may repair or replace the product, at their option, when the product is returned, prepaid, with proof of purchase. Alteration to, misuse of, or improper installation of this product voids the warranty. Curt Manufacturing Inc.'s liability is limited to repair or replacement of products found to be defective, and specifically excludes liability for incidental or consequential loss or damage.