

INSTALLATION MANUAL OF CROSS BAR FOR COROLLA 2019-

Care must be taken when installing this accessory to ensure damage does not occur to the vehicle. The installation of this accessory should follow approved guidelines to ensure a quality installation.

These guidelines can be found in the "Accessory Installation Practices" document.

This document covers such items as:-

- Vehicle Protection (use of covers and blankets, cleaning chemicals, etc.).
- Safety (eye protection, rechecking torque procedure, etc.).
- Vehicle Disassembly/Reassembly (panel removal, part storage, etc.).
- Electrical Component Disassembly/Reassembly (battery disconnection, connector removal, etc.).

Please see your Toyota dealer for a copy of this document.

1. Check the Kit & Warnings.

(a) Verify the kit contents (Fig. 1-1).

(1) A1 = Front cross bar (1 pc)

(2) A2 = Rear cross bars (1 pc)

(3) B = Part (4 pcs) & keys (2 pcs)

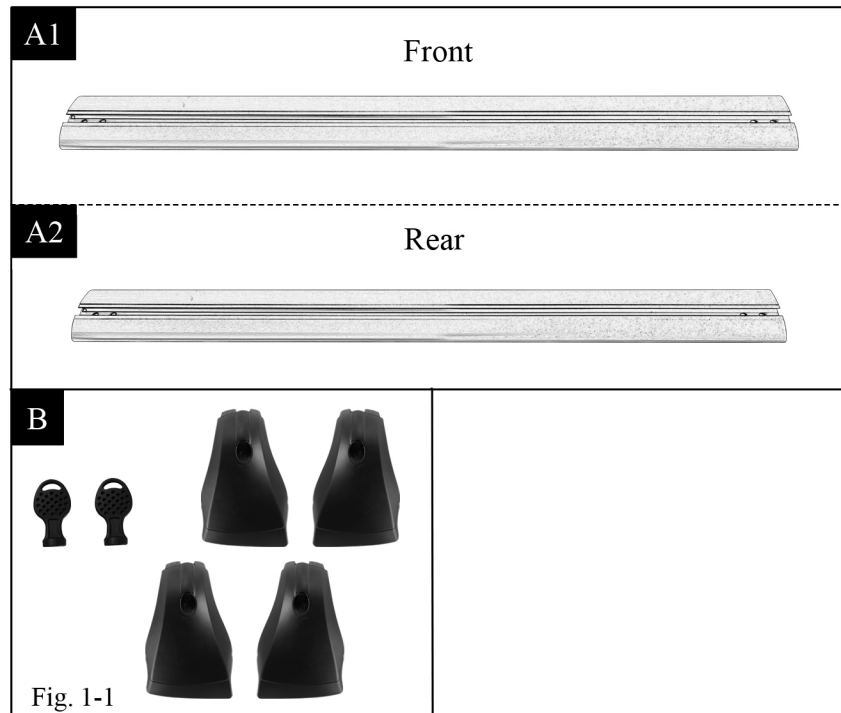

INSTALLATION STEPS



1. Open the upper cover with the key



2. State after opening



3. As shown in the picture, slide in the box screws, and then install the lower bottom cover



4. As shown in the picture, put in the spacers, and then tighten the screws



5. The installation is complete

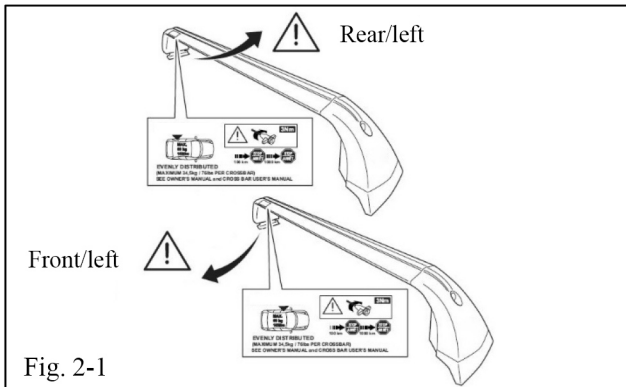

Fig. 2-1

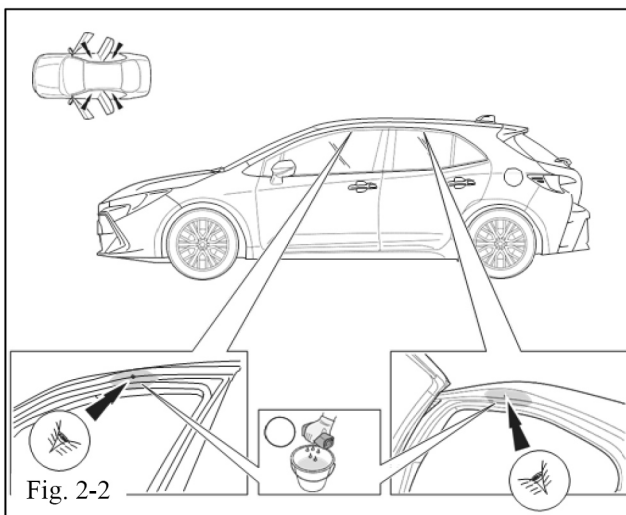

Fig. 2-2

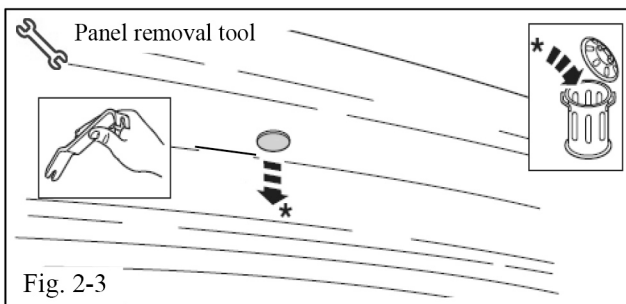

Fig. 2-3

2. Prepare to Install the Cross Bars.

- (a) Identify where on the vehicle each cross-bar foot will mount (Fig. 2-1).

⚠ NOTE: The warning label on the left side indicates the vehicle position, front or rear.

- (b) Protect the roof with a blanket if needed.

- (c) Open all four doors and clean the indicated mounting area with VDC-approved cleaner or soap and water solution (Fig. 2-2).

- (d) Use a plastic prying tool to remove the 4 caps and discard them (Fig. 2-3).

⚠ (e) Using scissors, neatly cut open the plastic bag containing the installation torque tool (item D) and the resealable bag of plastic inserts (item C).

- (f) Remove the 4 plastic inserts (item C) from the resealable plastic bag.

- (g) Retain the non-resealable bag for storage of the installation torque tool and keys.

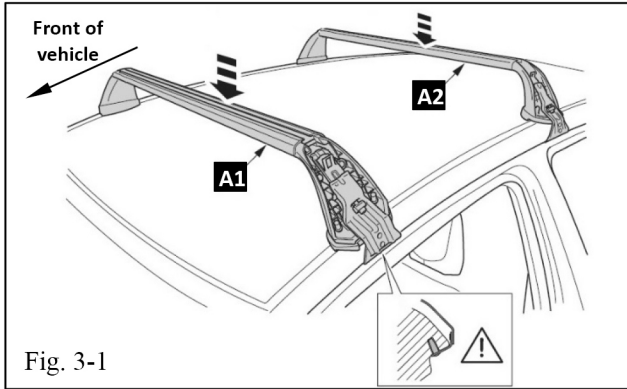

3. Install the Front and Rear Cross Bars

(a) Carefully place the front cross bar (item A1) where the pins are aligned with the front mounting holes (Fig. 3-1).

⚠ NOTE: Do not move or slide the cross bar along the vehicle body.

(b) Carefully place the rear cross bar (item A2) where the pins are aligned with the rear mounting holes (Fig. 3-1).

⚠ NOTE: Do not move or slide the cross bar along the vehicle body.

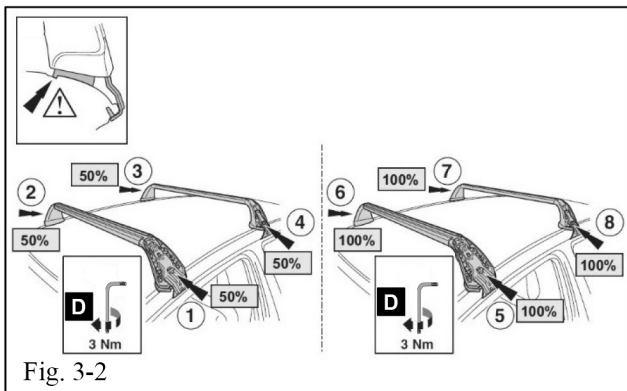

(c) Use one hand to fully seat the locating pin into the holes in the door frame, then use the provided installation torque tool (item D) to partially tighten (about 50%) each support (Fig. 3-2).

⚠ NOTE: Ensure that the cross-bar supports are placed properly onto the roof by making sure the rubber pad is fitted in the drip rail and the locating pins are fully seated into the holes in the door frame (Inset, Fig. 3-2).

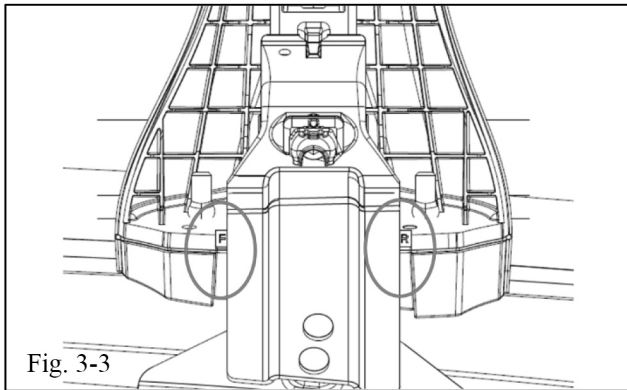

⚠ NOTE: Confirm bracket is center between F and R on cross bar bracket (Fig. 3-3).



⚠ NOTE: Confirm tightening mechanism is right-side up before tightening (Fig. 3-4).

(d) Tighten each support until the installation torque tool (item D) clicks (100%).



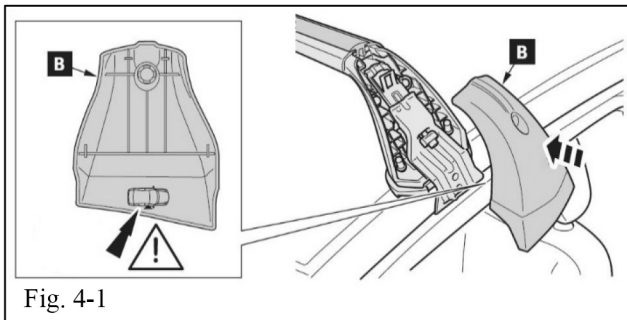

Fig. 4-1

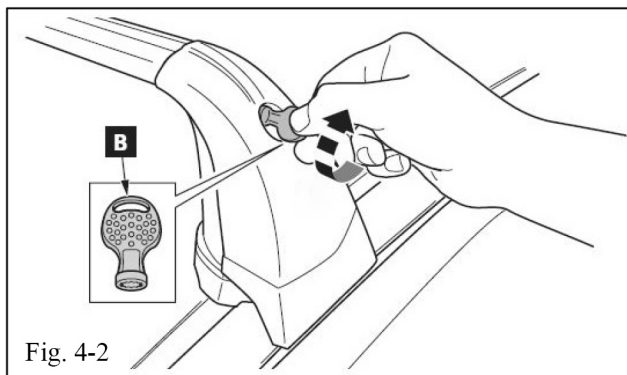

Fig. 4-2

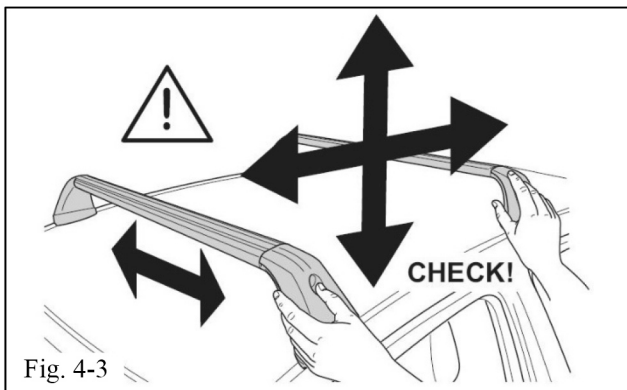

Fig. 4-3

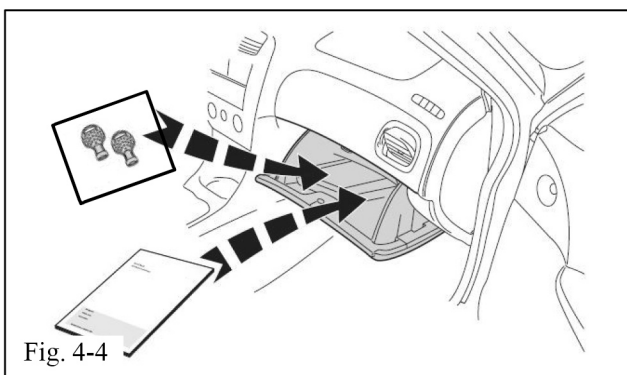



Fig. 4-4

4. Complete the Installation.

(a) Install the covers (item B) onto each support. Each cover has its location shown on the inside surface (Fig. 4-1).

 (b) Use one of the keys (item B) to lock the covers into position by turning the key clockwise approximately $\frac{1}{4}$ turn (Fig. 4-2).

 **NOTE:** Both keys are the same.

(c) Remove the key (item B) and place it in the original plastic bag.

(d) Check that the cross bars are tight and do not move (Fig. 4-3).

 (e) Place the manual and plastic bag [with cover keys and installation tool] in the glove compartment (Fig. 4-4).