

Part Number: PT924-47190

Kit Contents

Item #	Quantity Req.	Description
1	1	Rear Bumper Protector
2	1	Installation Instruction Sheet
3		

Hardware Bag Contents

Item #	Quantity Req.	Description

Additional Items Required For Installation

Item #	Quantity Req.	Description

Conflicts

None

Recommended Tools

Personal & Vehicle Protection	Notes
Vehicle Protection	
Special Tools	Notes
Surface Thermometer	Infrared Non-Contact
Heat Gun	Master Heat Gun HG-301A or equivalent
Installation Tools	Notes
Clean Lint Free Cloths	
Hard Rubber Hand Roller	1" to 3" wide i.e. Marshalltown E54D or Dynamat 10007
Special Chemicals	Notes
VDC Approved Cleaner	

General Applicability

MY19 and newer Prius models

Recommended Sequence of Application

Item #	Accessory

Vehicle Service Parts (may be required for reassembly)

Item #	Quantity Req.	Description

Legend



STOP: Damage to the vehicle may occur. Do not proceed until process has been complied with.



OPERATOR SAFETY: Use caution to avoid risk of injury.



CAUTION: A process that must be carefully observed in order to reduce the risk of damage to the accessory/vehicle and to ensure a quality installation.



TOOLS & EQUIPMENT: Used in Figures calls out the specific tools and equipment recommended for this process.



REVISION MARK: This mark highlights a change in installation with respect to previous issue.



SAFETY TORQUE: This mark indicates that torque is related to safety.



REGULATORY MARK: This mark indicates the component is related to regulatory compliance

Care must be taken when installing this accessory to ensure damage does not occur to the vehicle. The installation of this accessory should follow approved guidelines to ensure a quality installation.

These guidelines can be found in the "Accessory Installation Practices" document.

This document covers such items as:-

- Vehicle Protection (use of covers and blankets, cleaning chemicals, etc.).
- Safety (eye protection, rechecking torque procedure, etc.).
- Vehicle Disassembly/Reassembly (panel removal, part storage, etc.).
- Electrical Component Disassembly/Reassembly (battery disconnection, connector removal, etc.).

Please see your Toyota dealer for a copy of this document.

1. Prepare the Vehicle

(a) Open the package and check the part for damage.

⚠ (b) Ensure the rear bumper protector and the vehicle bumper is between 60°-110°F (15°-43°C).

(c) Open the trunk lid.

(d) Use VDC approved cleaner on a clean lint free cloth and scrub the top surface of the rear bumper (Fig. 1-1).

(e) Wipe the scrubbed bumper surface with a clean, dry, lint free cloth.

⚠ **NOTE:** Once cleaned, do not contaminate this surface by touching it with bare skin.

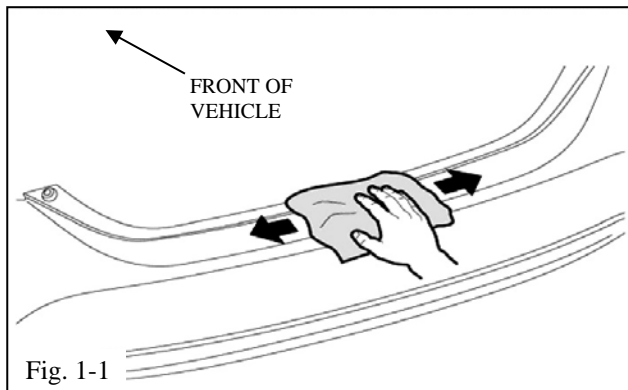

2. Install the Rear Bumper Protector

(a) While carefully holding the rear bumper protector by its edges, pull the all the plastic liner tabs at the ends of the tapes to expose approximately 1½" (40mm) of tape (Fig. 2-1).

⚠ **NOTE:** Once the liner is removed from the rear bumper protector the surface of the tape must not be touched.

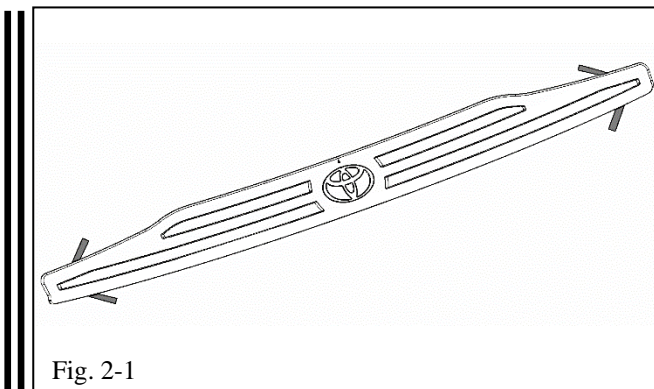

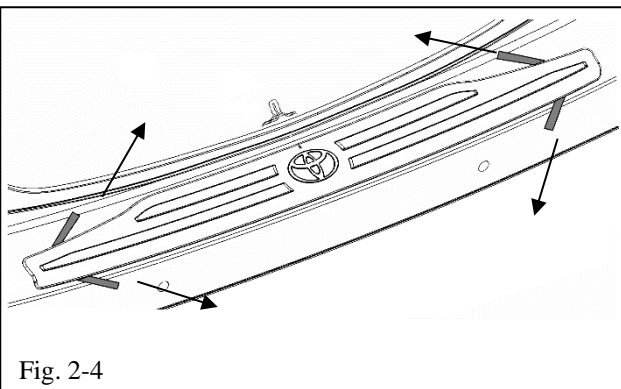
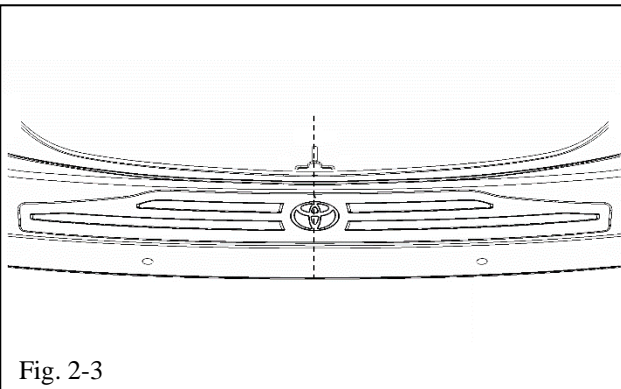
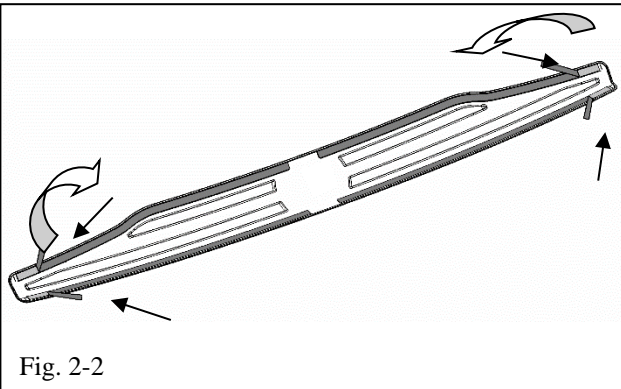

(b) Ensure all the tabs are folded so they can be accessed from the top once the protector is seated on the rear bumper (Fig. 2-2).

(c) Before installing the rear bumper protector, ensure the central arrow is aligned with the center of the vehicle or lift gate striker (Fig. 2-3).

(d) While keeping the Rear Bumper Protector aligned, lower the right-hand corner until it contacts the bumper and starts to stick. Using a rolling motion, press the rest of the protector from right to left. **Do not** allow both ends of the protector to stick to the bumper before the center touches

(e) Once the exposed tape has been secured, pull out and discard all the liners to allow full tape contact with the rear bumper (Fig. 2-4).

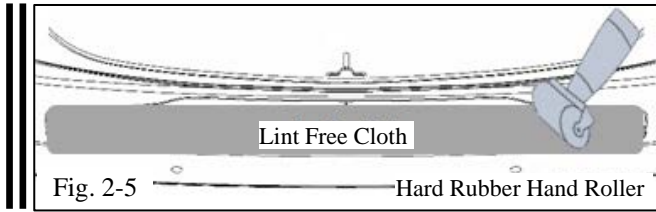

- !** (f) Press down on the rear bumper protector firmly. Then place the lint free towel on top of assembled rear bumper protector and slowly use the hard rubber hand roller to roll firmly on and around the entire perimeter of the protector to ensure full adhesion of the tape to the rear bumper (Fig. 2-5).

3. Complete the Installation

- (a) Close the trunk lid.

