

460 HORIZON DR. | SUWANEE, GA 30024 | PHONE: 770-614-6101 | FAX: 844-270-0593 | www.Omix-ADA.com

Front Fender Chop Bracket with DRL Light, JL & JT Non-Rubicon

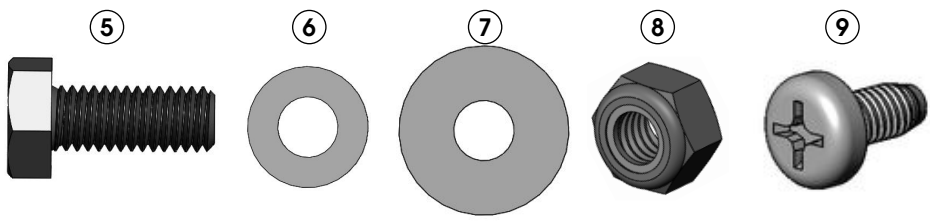
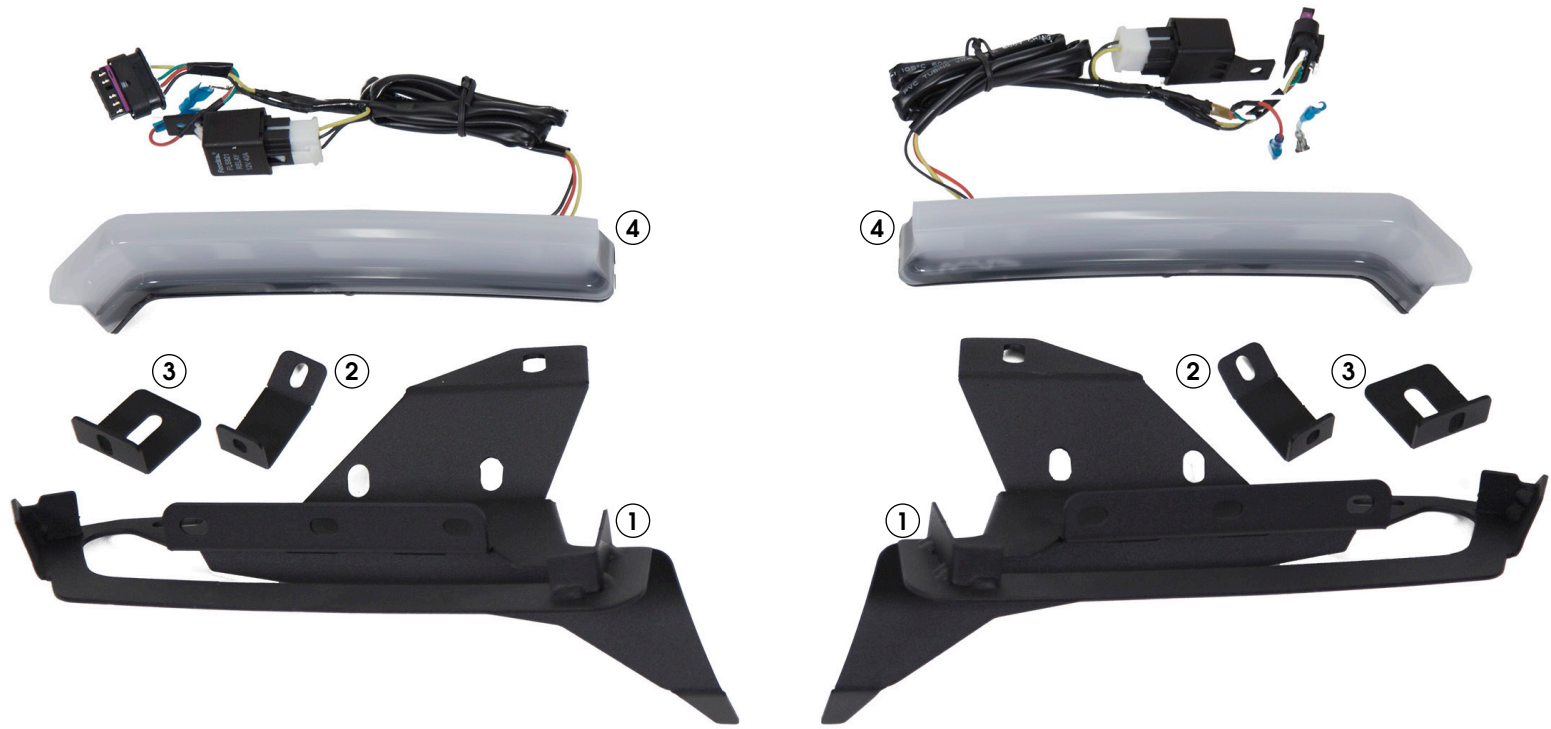

Components

1. Main Bracket, Driver and Passenger Side	2	6. Flat Washer M6 SM OD , Black Finish	14
2. Bracket to Fender Top, Driver and Passenger Side	2	7. Flat Washer M6 LG OD, Black Finish	4
3. Bracket to Fender Side, Driver and Passenger Side	2	8. Nylock Hex Nut M6 x 1.0, Black Finish.....	8
4. DRL Light Assy., Driver and Passenger Side	2	9. Screw Phillips Head M6 x 12	6
5. Hex Head Bolt M6 x 15mm, Black Finish.....	8		

OMIX-ADA® TECHNICAL SUPPORT
 PHONE: M-F 8am - 5pm EST 1-800-449-6649
 FOR WARRANTY OR TECH CONCERNS EMAIL: webmaster@omixsupport.com

ATTN: STATE OF CALIFORNIA CONSUMERS
⚠ WARNING: Cancer and Reproductive Harm - www.P65Warnings.ca.gov.

Front Fender Chop Bracket with DRL Light, JL & JT Non-Rubicon

1. Start by releasing the inner fender from the body of the Jeep. Remove 4 bolts with 10mm wrench, these bolts are marked with red arrows in the picture.

There is one smaller bolt attaching the fender liner to the back of the light housing, remove it using a 8mm wrench.



2. Use a pry tool to remove the push rivets holding the liner to the body of the Jeep.

Lightly pull the inner fender liner to check it's completely loose. If not check the area for any missed hardware.



3. To remove the fender from the body start from either the bottom corner or front and pull away. The fender is attached with clips to the body, yanking the fender is the best method to release.

As the fender is released, rest the fender on the fender brackets. Next the light harness must be released. The harness has a red tab that needs to be pulled out and then press the clip, then pull apart to remove.

(Images are of Rubicon model but same steps apply for non-Rubicon models)



Front Fender Chop Bracket with DRL Light, JL & JT Non-Rubicon

4. Make sure the fender is on a clean soft surface to avoid scratches. Place with the bottom of the fender up.

At this point you can choose to completely remove the inner plastic liner to create the most tire clearance. To do this drill each rivet along the fender's edge and the liner can be removed. We suggest installing our aluminum inner fender liners for the best look and protection.

If your keeping the liner peel back the front section to reach the hardware holding the light to the fender. Do not crease the plastic as you want the liner to return to its place. There is one rivet holding the front flap to the light, drill or pry the rivet out.



5. Using a T25 torx bit remove the four screws holding the rear brace to the light. Next use a T30 torx bit to remove the remaining screws. With all the screws removed the rear brace can be removed.

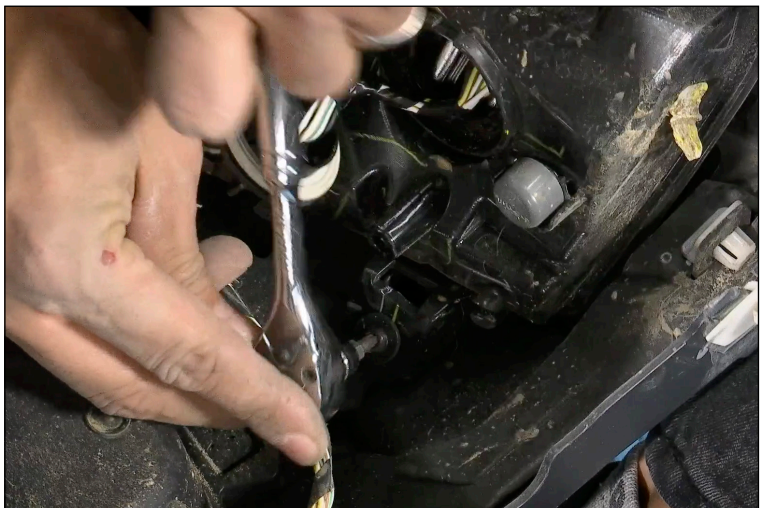

6. With the rear brace removed it exposes another T30 torx screw that holds the side marker light in place. Remove this screw and remove the marker light.

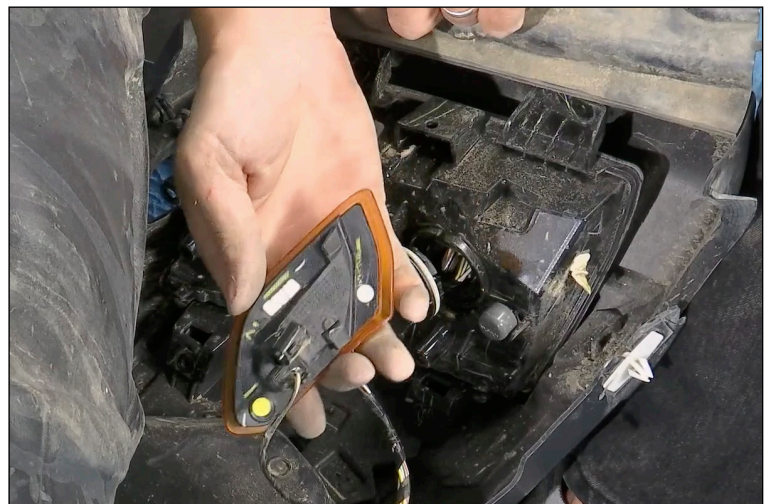

Front Fender Chop Bracket with DRL Light, JL & JT Non-Rubicon

7. The light is still attached with adhesive to the fender. Firmly grab the light housing to pull the adhesive tape away to remove light from the fender.



8. Remove the light harness from the fender. You'll have to pull back the liner to expose the retainers to pull from the fender. If you struggle pulling the retainers away either use the pry tool to remove or cut the retainers with snips.



9. Now remove the plastic surround of the light. There is a clip holding the plastic to the fender. Pry and remove this clip. Next use a utility knife or snips to cut the plastic surround to release the side closest to the inside of the fender.



Front Fender Chop Bracket with DRL Light, JL & JT Non-Rubicon

10. With the outside edge of the fender cut the light surround from the fender. You will be further trimming this item to meet the Chop Bracket. So don't cut the surround to high.



11. Each light is marked L (Passenger Side) and R (Drivers Side). Take the light and plug to the OE harness. Be sure to press the gray tab in after the harness is fully pushed in, this will lock it together. Lay the wire of the light in the fender braces. Take tie wraps and secure the wire to the braces.



12. Reinstall all the fender clips to the fender. Then attach the fender back to the Jeep.

Note: Use M6 bolts with washers to replace the OE clips in the locations noted here. This will secure the fender to the Jeep better than the OE clips. It's also an alternative mounting method in case you had any clips broken.



Front Fender Chop Bracket with DRL Light, JL & JT Non-Rubicon

13. Place the Chop Bracket into place. You are using it to mark the areas you must trim further. Remember the phrase "Less is Best" concerning cutting. Trim and return the bracket in place to check your cut, trim more as needed. This will assure the tightest and cleanest fit. Remove any sharp edges with sandpaper if needed.

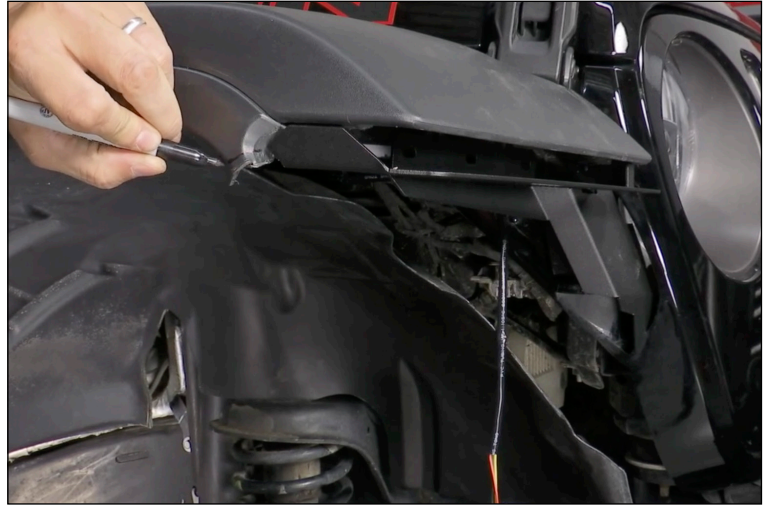
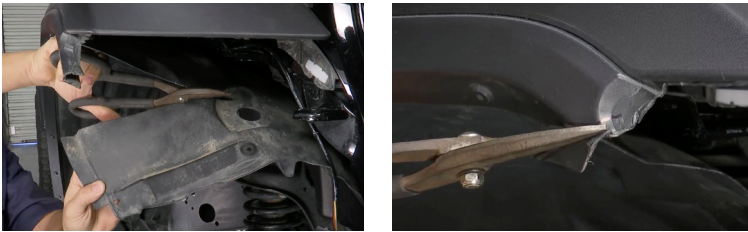

14. Install the bracket to fender brackets to the main bracket. The fender top side bracket mounts as shown in "A". Use M6 hardware to attach.

The fender side bracket mounts as shown in "B". Use M6 hardware to attach.

In both cases don't fully tighten. You'll need the bracket to shift to align fitment to the fender.

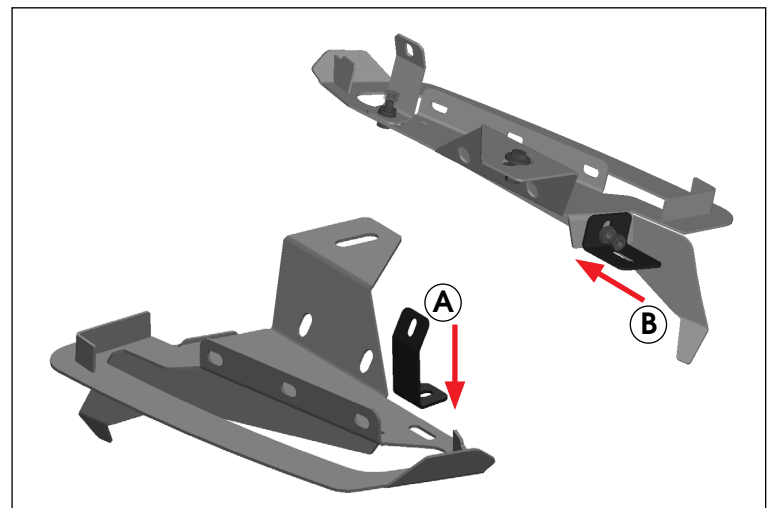

15. Attach the light assembly to the bracket using the three self tapping screws with washers. There is no need to over tighten the screws, avoid stripping the screw in the plastic light housing.



Front Fender Chop Bracket with DRL Light, JL & JT Non-Rubicon

16. Place the bracket into place. Have the top of the chop bracket (circled in lower image) rest on the upper fender mount, use M6 bolt, washers and nut to attach. Then attach side bracket to the lower fender mount use M6 hardware. The last fender mount will use the OE screw to attach into the plastic fender structure. Adjust the chop bracket to meet fender flush and level then fully tighten all three bolts.

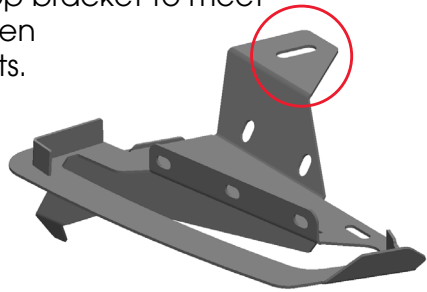

17. Attach the inner fender to the body of the Jeep using the same hardware (bolts and push rivets) you removed earlier.

Apply the same steps to the other side, this completes the installation.

